

# SPARE PARTS DRAWING

2018

1. PRUNING SAW
2. FOLDING SAW
3. POLE SAW
4. PRUNING SHEARS
5. FRUITS PRUNERS
6. LONG REACH PRUNERS
7. HEDGE SHEARS
8. LOPPING SHEARS
9. OTHER SHEARS









PS-32LL

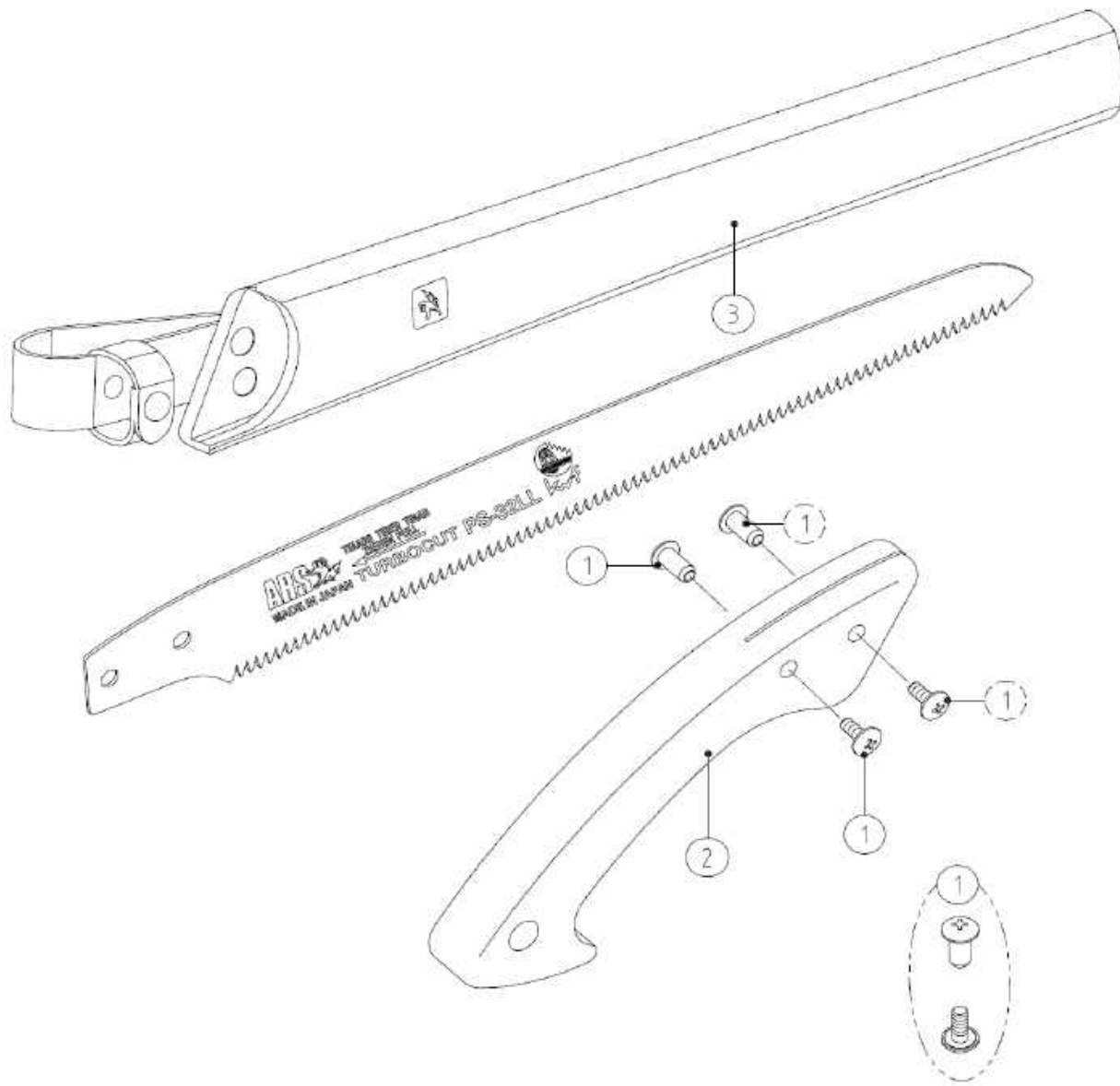

PARTS NO. SPECIFICATION	PARTS NO. SPECIFICATION
① SP-94 BOLT & NUT FOR PS-32L/LL (1PC EACH)	
② SP-321 WOODEN GRIP FOR PS-32L/LL	
③ SH-32 EX SHEATH FOR PS-30KL	





CAM-18PRO / CAM-24PRO

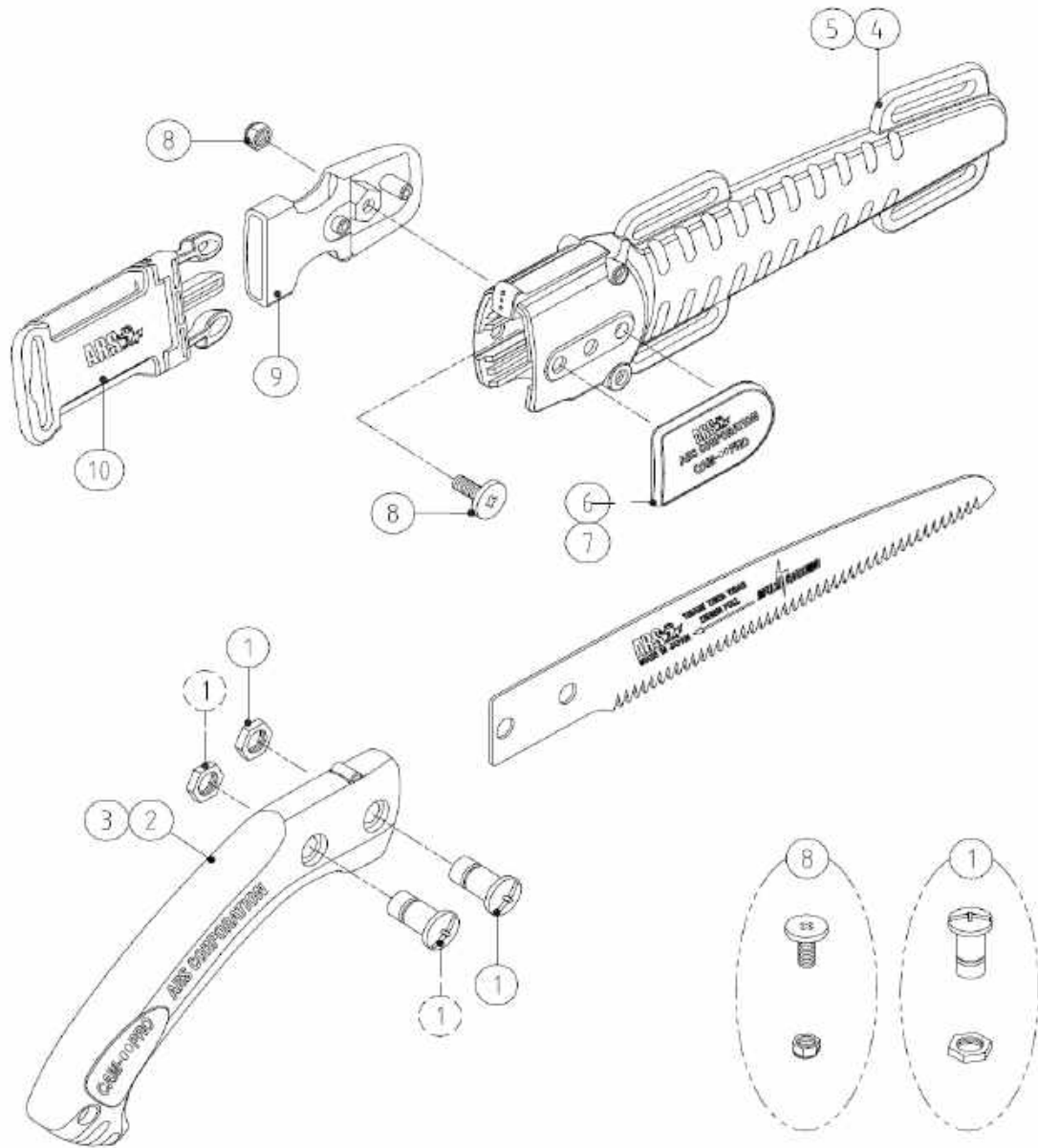

PARTS NO.	SPECIFICATION	PARTS NO.	SPECIFICATION
① SP-359	BOLT & NUT FOR CAM/CT/UV/CTR/UVR-PRO SERIES (1PC EACH)		
② SP-360	GRIP FOR CAM-18PRO		
③ SP-361	GRIP FOR CAM-24PRO		
④ SP-362	SHEATH ONLY, FOR CAM-18PRO (WITHOUT NAME PLATE OR BELT CLIP)		
⑤ SP-363	SHEATH ONLY, FOR CAM-24PRO (WITHOUT NAME PLATE OR BELT CLIP)		
⑥ SP-364	NAME PLATE FOR CAM-18PRO		
⑦ SP-365	NAME PLATE FOR CAM-24PRO		
⑧ SP-366	BOLT & NUT FOR THE BELT CLIP OF CAM/CT/UV/CTR/UVR-PRO SERIES		
⑨ SP-367	BELT CLIP FOR CAM/CT/UV/CTR/UVR-PRO SERIES		
⑩ SP-429	BELT FOR CAM/CT/UV-PRO SERIES		



UV-34 / CT-34

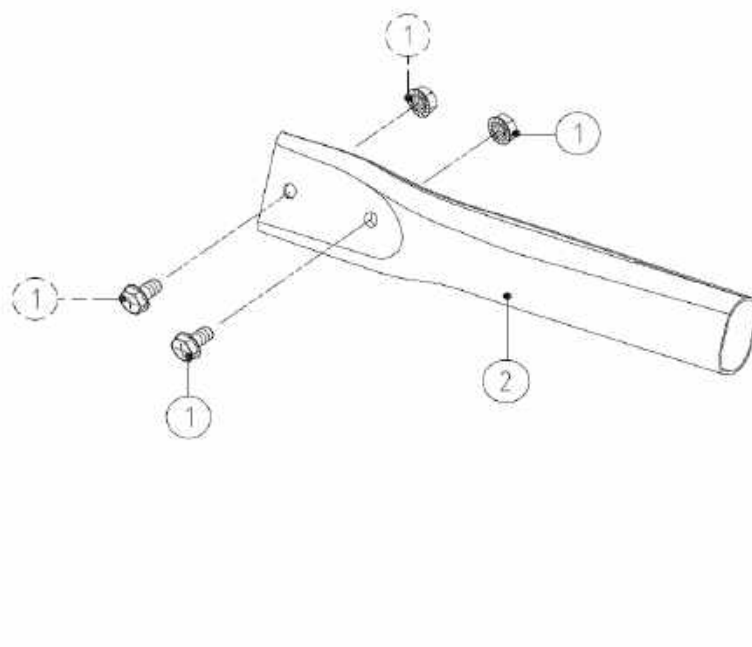
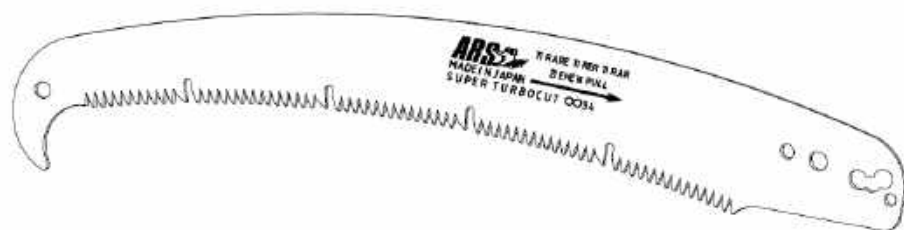

PARTS NO. SPECIFICATION	PARTS NO. SPECIFICATION
① SP-146 BOLT & NUT FOR CT/UV-32PRO-EXP/-34, UV-40/-47JG-1/-2/-3	
② JG-2 EX GRIP ONLY, FOR UV/CT-34 & UV/CT-32PRO-EXP	





CTR-32PRO / UVR-32PRO

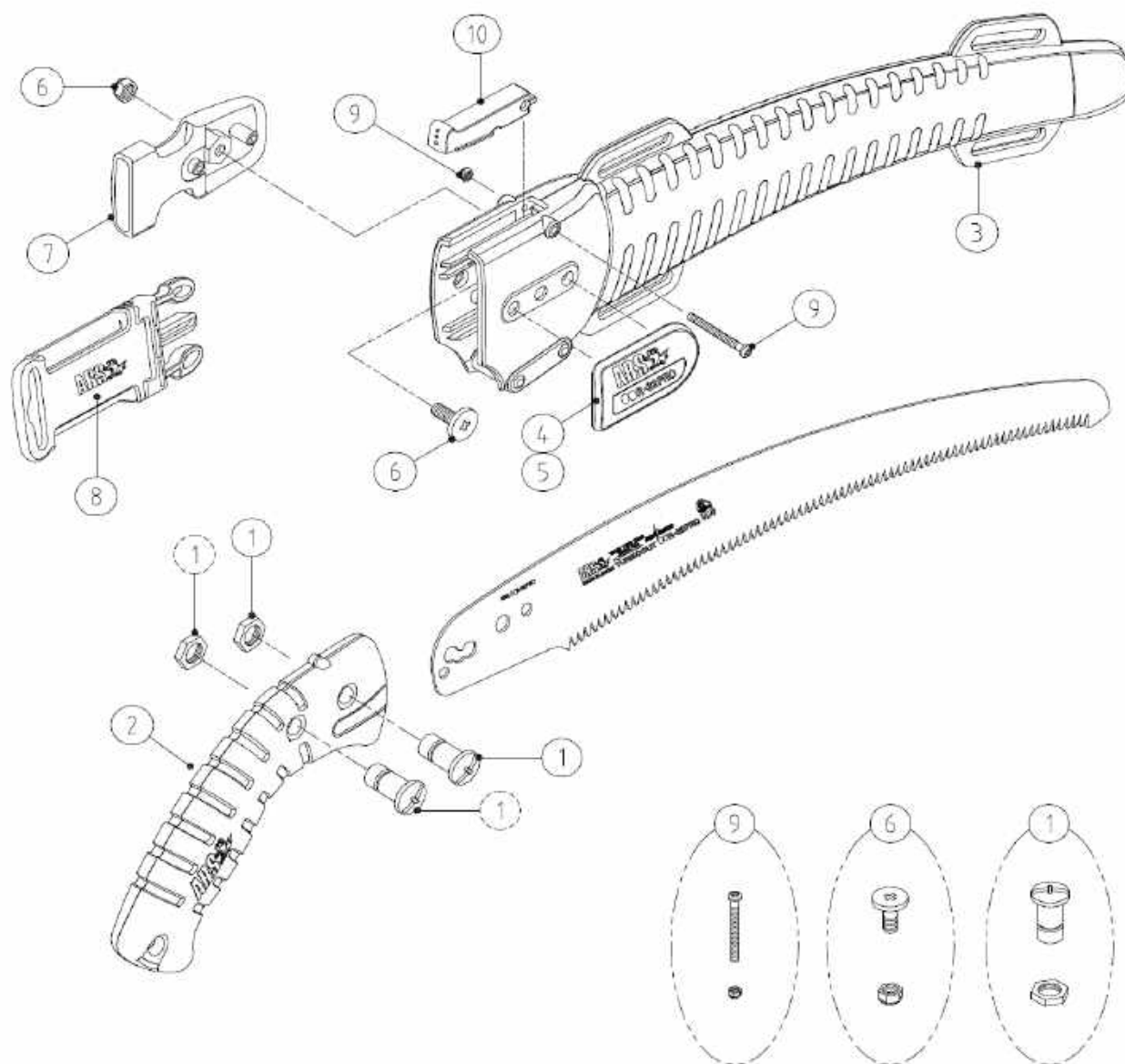

PARTS NO.	SPECIFICATION	PARTS NO.	SPECIFICATION
① SP-359	BOLT & NUT FOR CAM/CT/UV/CTR/UVR-PRO SERIES (1PC EACH)		
② SP-455	GRIP FOR CTR/UVR-32PRO		
③ SP-456	SHEATH FOR CTR/UVR-32PRO (W/O STOPPER, NAME PLATE OR BELT CLIP)		
④ SP-457	NAME PLATE FOR CTR-32PRO		
⑤ SP-458	NAME PLATE FOR UVR-32PRO		
⑥ SP-366	BOLT & NUT FOR THE BELT CLIP OF CAM/CT/UV/CTR/UVR-PRO SERIES		
⑦ SP-367	BELT CLIP FOR CAM/CT/UV/CTR/UVR-PRO SERIES		
⑧ SP-429	BELT FOR CAM/CT/UV/CTR/UVR SERIES		
⑨ SP-373	BOLT & NUT FOR STOPPER OF CT/UV/CTR/UVR-32PRO/-EXP, 37PRO & 42PRO		
⑩ SP-372	STOPPER FOR CT/UV/CTR/UVR-32PRO, 37PRO & 42PRO		











CT-37PRO / UV-37PRO

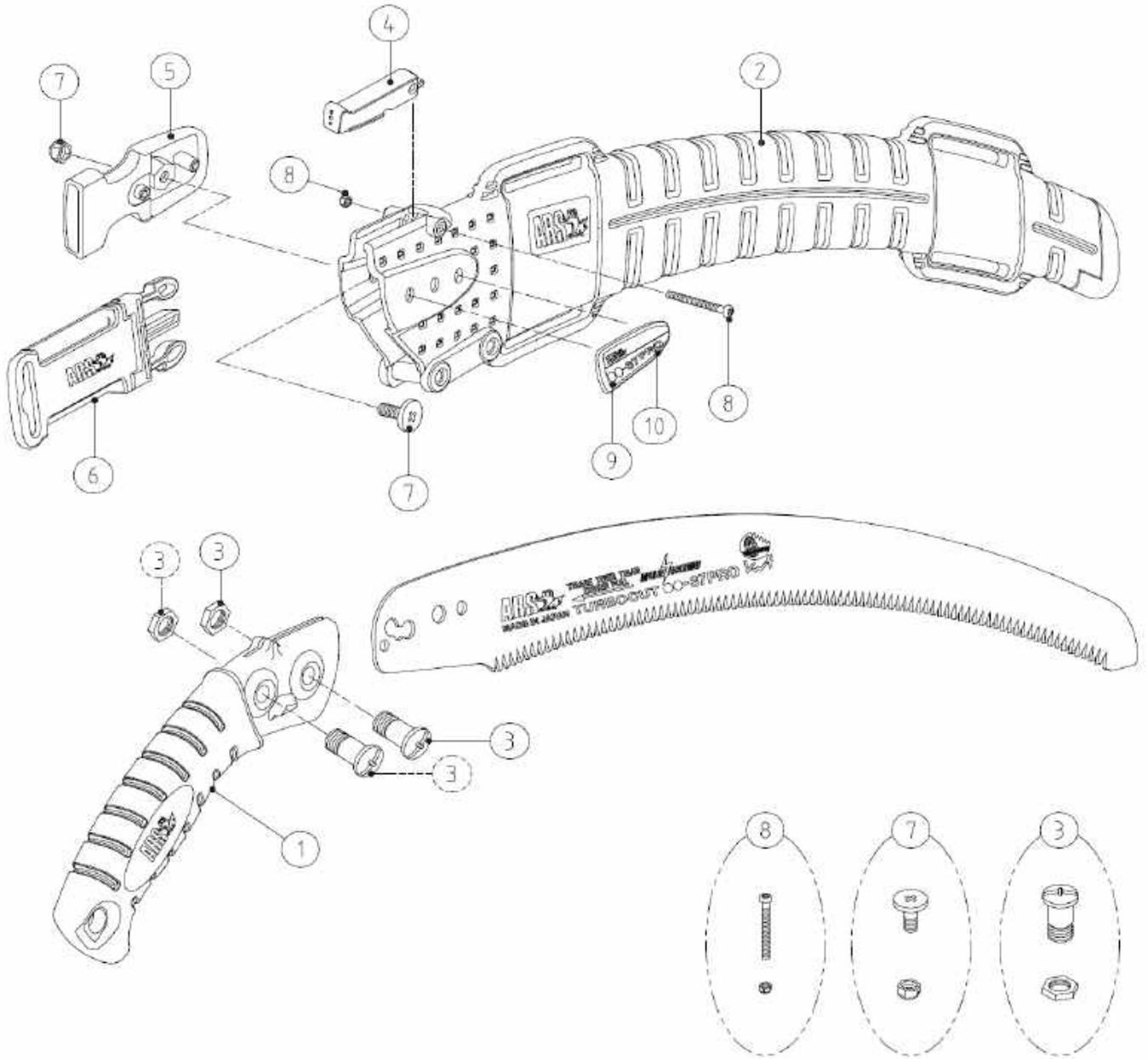

PARTS NO.	SPECIFICATION	PARTS NO.	SPECIFICATION
①	SP-427 GRIP FOR CT/UV-37PRO/42PRO		
②	SP-428 SHEATH FOR CT/UV-37PRO/42PRO (W/O STOPPER,NAME PLATE OR BELT CLIP)		
③	SP-359 BOLT & NUT FOR CAM/CT/UV/CTR/ UVR-PRO SERIES (1PC EACH)		
④	SP-372 STOPPER FOR CT/UV/CTR/UVR-32PRO/ 37PRO/42PRO		
⑤	SP-367 BELT CLIP FOR CAM/CT/UV/CTR/ UVR-PRO SERIES		
⑥	SP-429 BELT FOR CAM/CT/UV/CTR/UVR-PRO SERIES		
⑦	SP-366 BOLT & NUT FOR THE BELT CLIP OF CAM/CT/UV/CTR/UVR-PRO SERIES		
⑧	SP-373 BOLT & NUT FOR STOPPER OF CT/UV/CTR/ UVR-32PRO/-EXP/37PRO/42PRO		
⑨	SP-430 NAME PLATE FOR CT-37PRO		
⑩	SP-431 NAME PLATE FOR UV-37PRO		

CT-42PRO / UV-42PRO

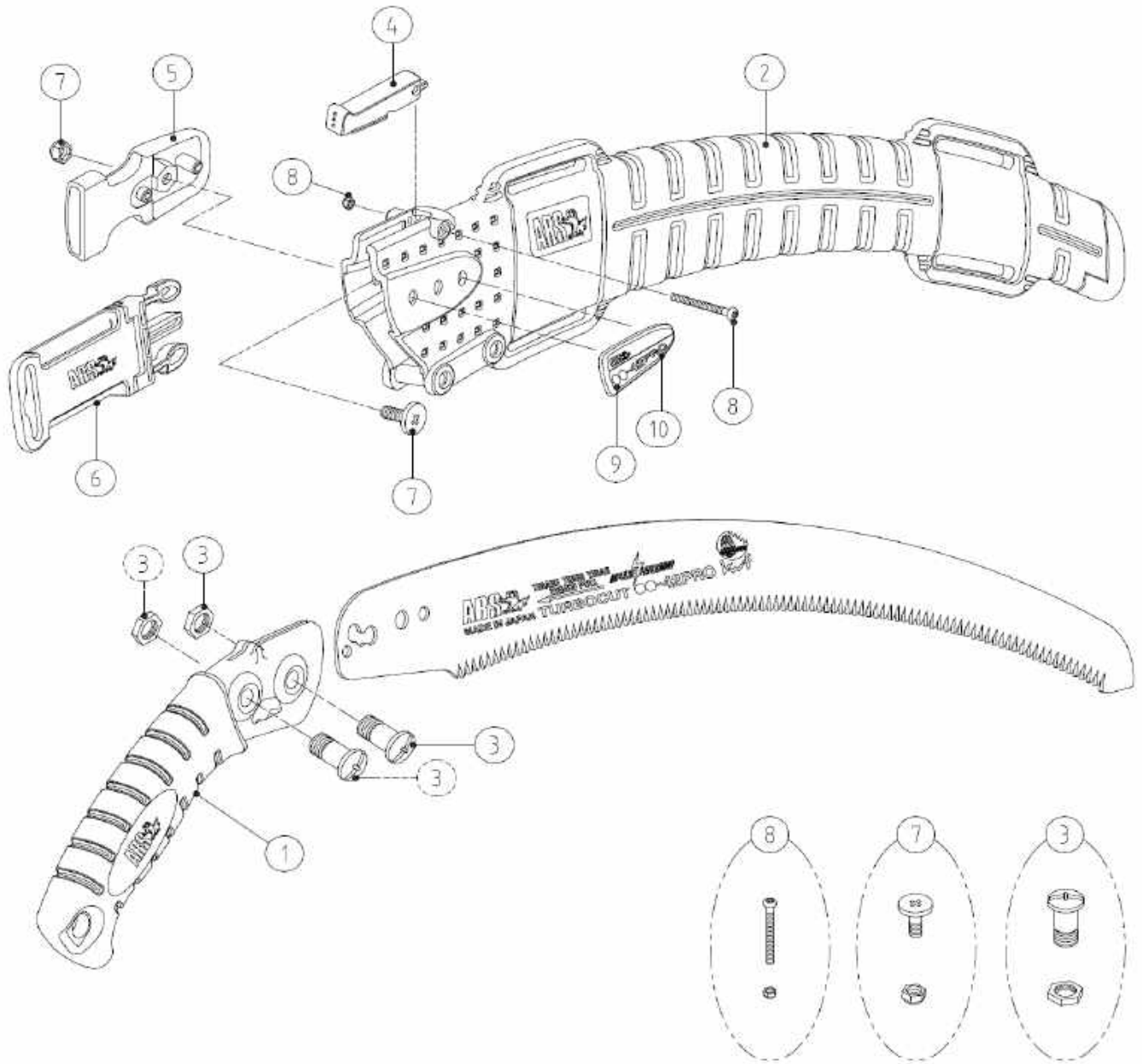

PARTS NO.	SPECIFICATION	PARTS NO.	SPECIFICATION
①	SP-427 GRIP FOR CT/UV-37PRO/42PRO		
②	SP-428 SHEATH FOR CT/UV-37PRO/42PRO (W/O STOPPER,NAME PLATE OR BELT CLIP)		
③	SP-359 BOLT & NUT FOR CAM/CT/UV/CTR/ UVR-PRO SERIES (1PC EACH)		
④	SP-372 STOPPER FOR CT/UV/CTR/UVR-32PRO/ 37PRO/42PRO		
⑤	SP-367 BELT CLIP FOR CAM/CT/UV/CTR/ UVR-PRO SERIES		
⑥	SP-429 BELT FOR CAM/CT/UV/CTR/UVR-PRO SERIES		
⑦	SP-366 BOLT & NUT FOR THE BELT CLIP OF CAM/CT/UV/CTR/UVR-PRO SERIES		
⑧	SP-373 BOLT & NUT FOR STOPPER OF CT/UV/CTR/ UVR-32PRO/-EXP/37PRO/42PRO		
⑨	SP-443 NAME PLATE FOR CT-42PRO		
⑩	SP-444 NAME PLATE FOR UV-42PRO		



Z-17

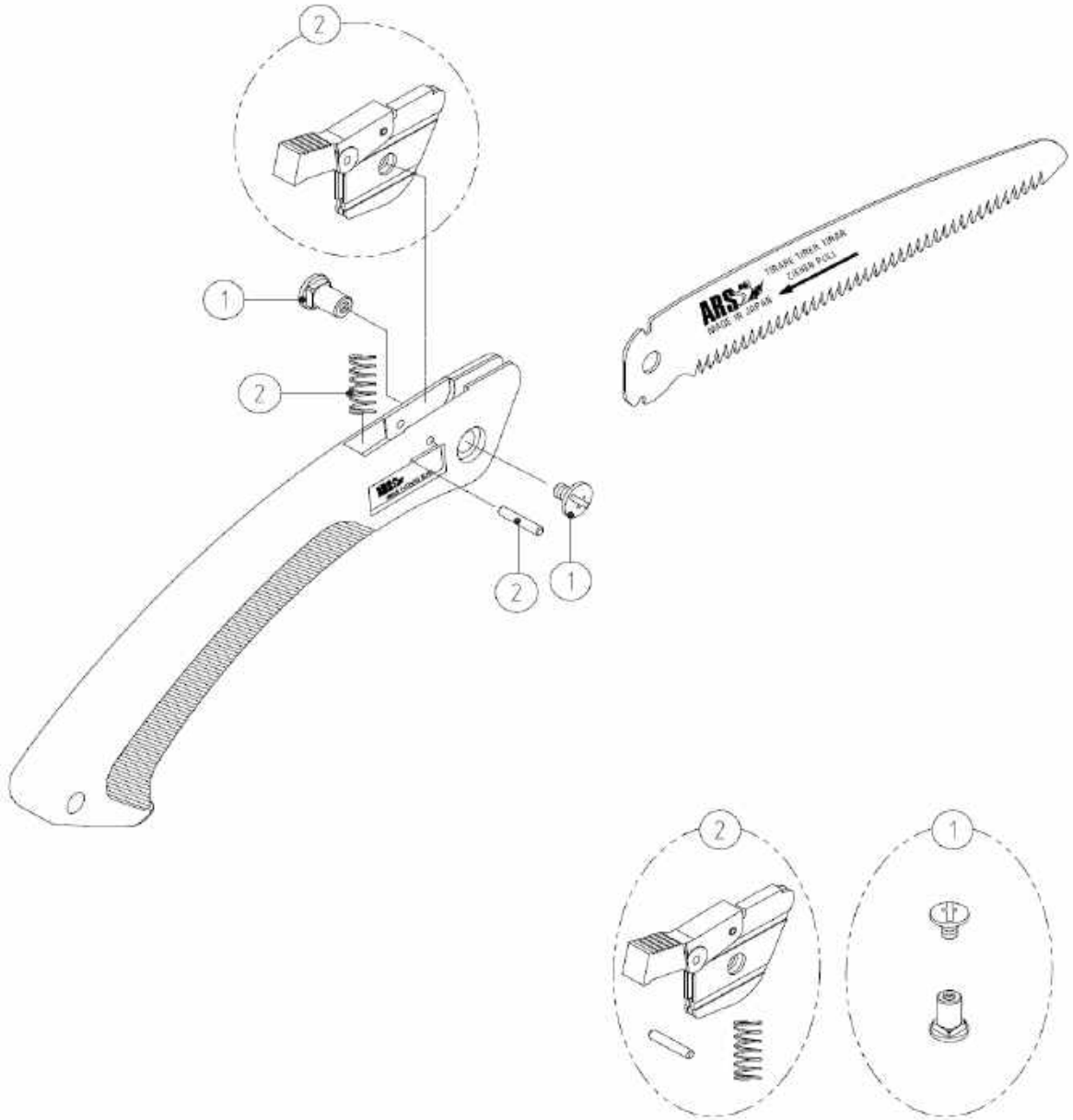

PARTS NO. SPECIFICATION	PARTS NO. SPECIFICATION
① SP-118 BOLT & NUT FOR Z-17/G-17/GR-17	
② SP-182 STOPPER SET FOR Z-17/G-17/GR-17	







EXP-3.3 / EXP-4.5 / EXP-5.5

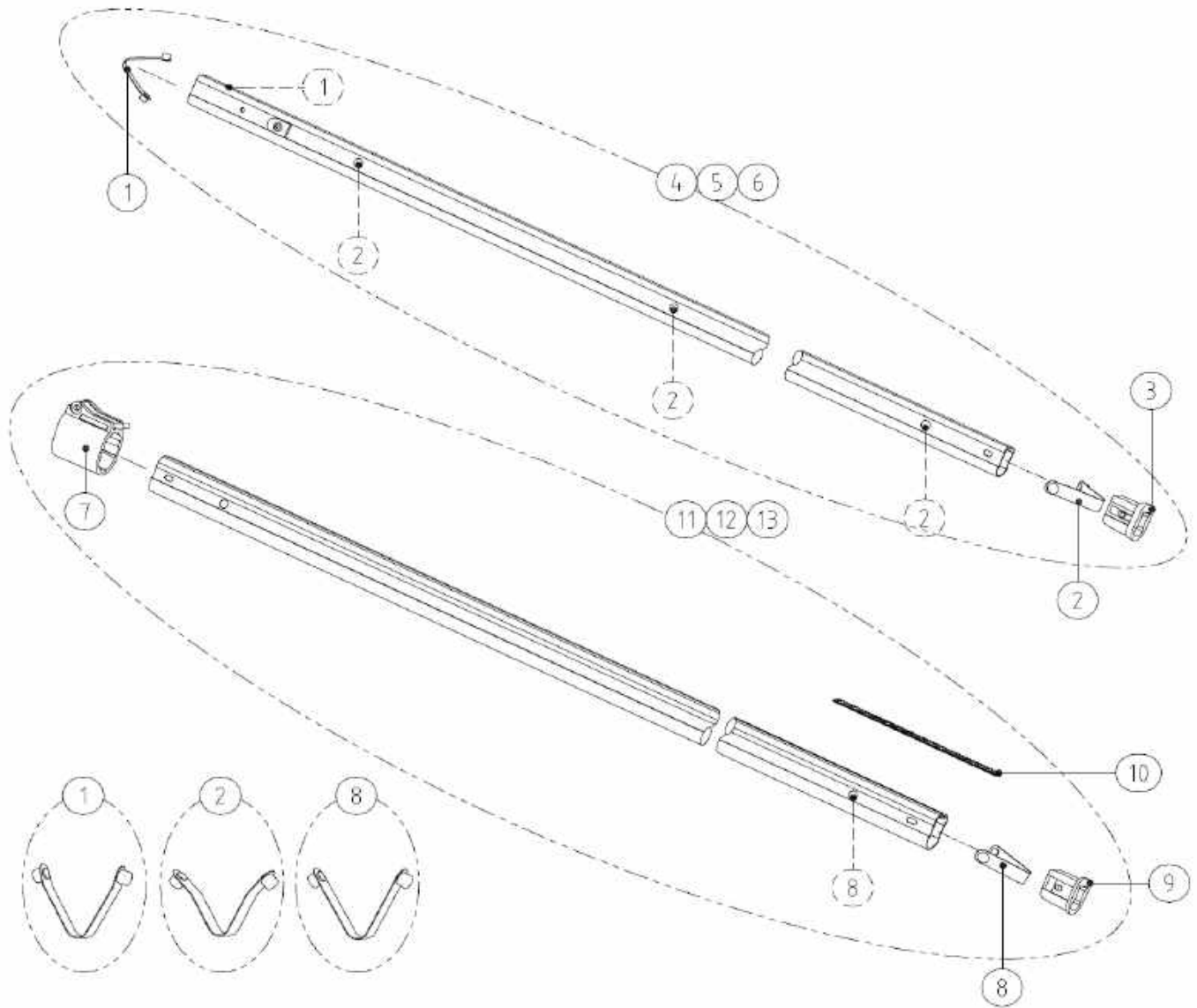

PARTS NO.	SPECIFICATION	PARTS NO.	SPECIFICATION
① SP-453	PRESS BUTTON W/SPRING, BENT INSIDE, FOR EXP SERIES	⑩ SP-111	PLASTIC GUIDE FOR EXP-4.5/EXP-5.5 (1 PC.)
② SP-454	PRESS BUTTON W/SPRING, BENT OUTSIDE, FOR EXP SERIES	SP-111-A	PLASTIC GUIDE SET FOR EXP-4.5 (6 PCS.)
③ SP-120	ENDCAP FOR C PIPE OF EXP SERIES	SP-111-B	PLASTIC GUIDE SET FOR EXP-5.5 (8 PCS.)
④ SP-329	UPPER PIPE (C PIPE) OF EXP-2.3/3.3	SP-111-C	PLASTIC GUIDE SET FOR EXP-3.3 (5 PCS.)
⑤ SP-117	UPPER PIPE (C PIPE) OF EXP-4.5	⑪ SP-328	MIDDLE PIPE (B PIPE) OF EXP-3.3
⑥ SP-104	UPPER PIPE (C PIPE) OF EXP-5.5	⑫ SP-116	MIDDLE PIPE (B PIPE) OF EXP-4.5
⑦ SP-113-A	STOPPER SET FOR MIDDLE PIPE (B PIPE) OF EXP-4.5	⑬ SP-103	MIDDLE PIPE (B PIPE) OF EXP-5.5
SP-113-B	STOPPER SET FOR MIDDLE PIPE (B PIPE) OF EXP-5.5		
SP-113-D	STOPPER SET FOR MIDDLE PIPE (B PIPE) OF EXP-3.3		
⑧ SP-110	PRESS BUTTON W/SPRING, W/O BENDING, FOR EXP SERIES		
⑨ SP-119	ENDCAP FOR B PIPE OF EXP SERIES		



EXP-3.3 / EXP-4.5 / EXP-5.5

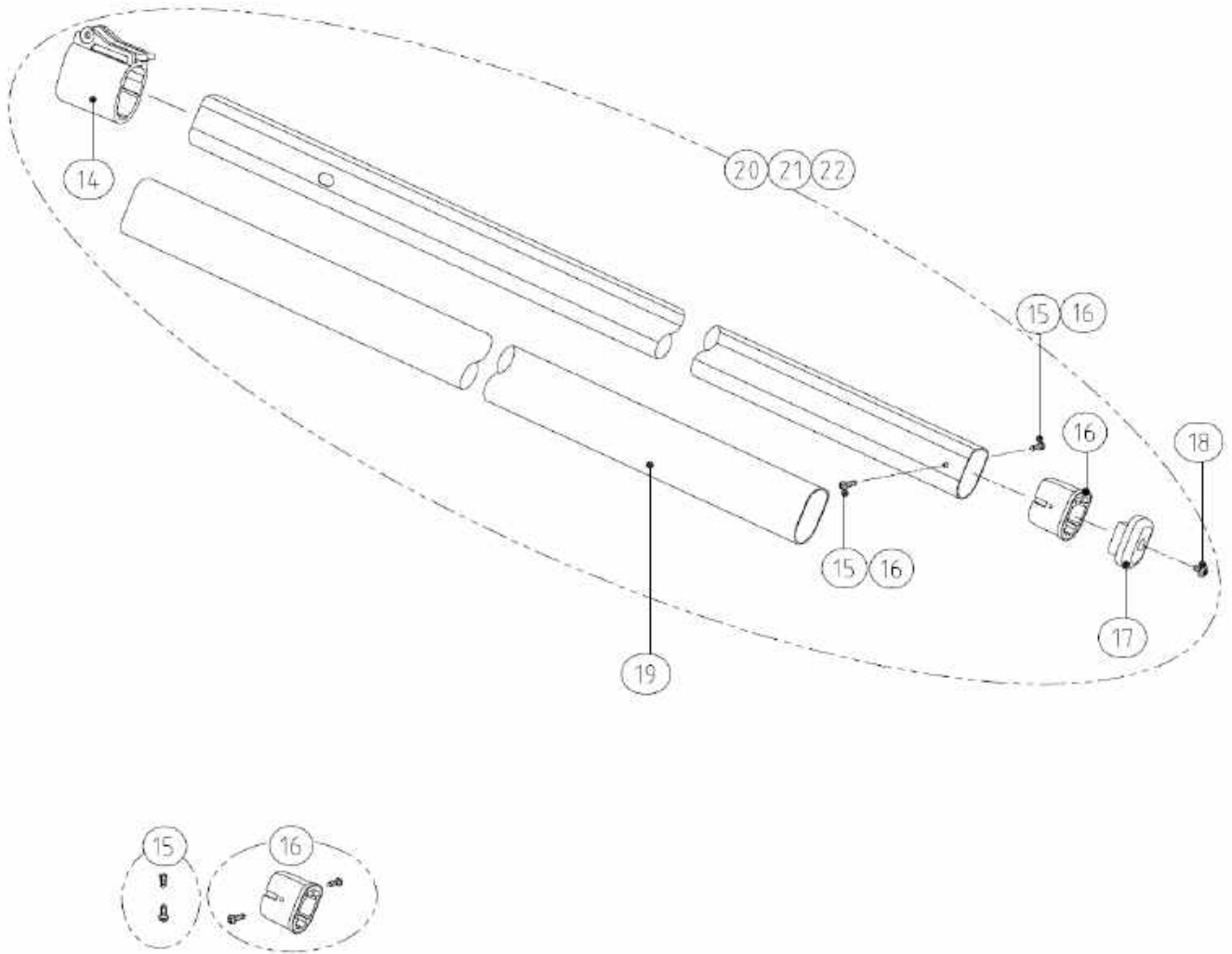

PARTS NO.	SPECIFICATION	PARTS NO.	SPECIFICATION
⑭	SP-114 STOPPER SET FOR LOWER PIPE (A PIPE) OF EXP SERIES		
⑮	SP-121 SCREW FOR ENDCAP A OF EXP SERIES (2PCS)		
⑯	SP-115 ENDCAP FOR A PIPE OF EXP SERIES WITH 2 SCREWS		
⑰	SP-330 RUBBER CUSHION FOR EXP SERIES		
⑱	SP-331 SCREW TO ATTACHED THE RUBBER CUSHION FOR EXP SERIES		
⑲	SP-122 GRIP COVER FOR A PIPE OF EXP SERIES		
⑳	SP-327 LOWER PIPE (A PIPE) OF EXP-3.3 WITH GRIP COVER		
㉑	SP-112 LOWER PIPE (A PIPE) OF EXP-4.5 WITH GRIP COVER		
㉒	SP-102 LOWER PIPE (A PIPE) OF EXP-5.5 WITH GRIP COVER		

EXW-1.8 / EXW-2.7

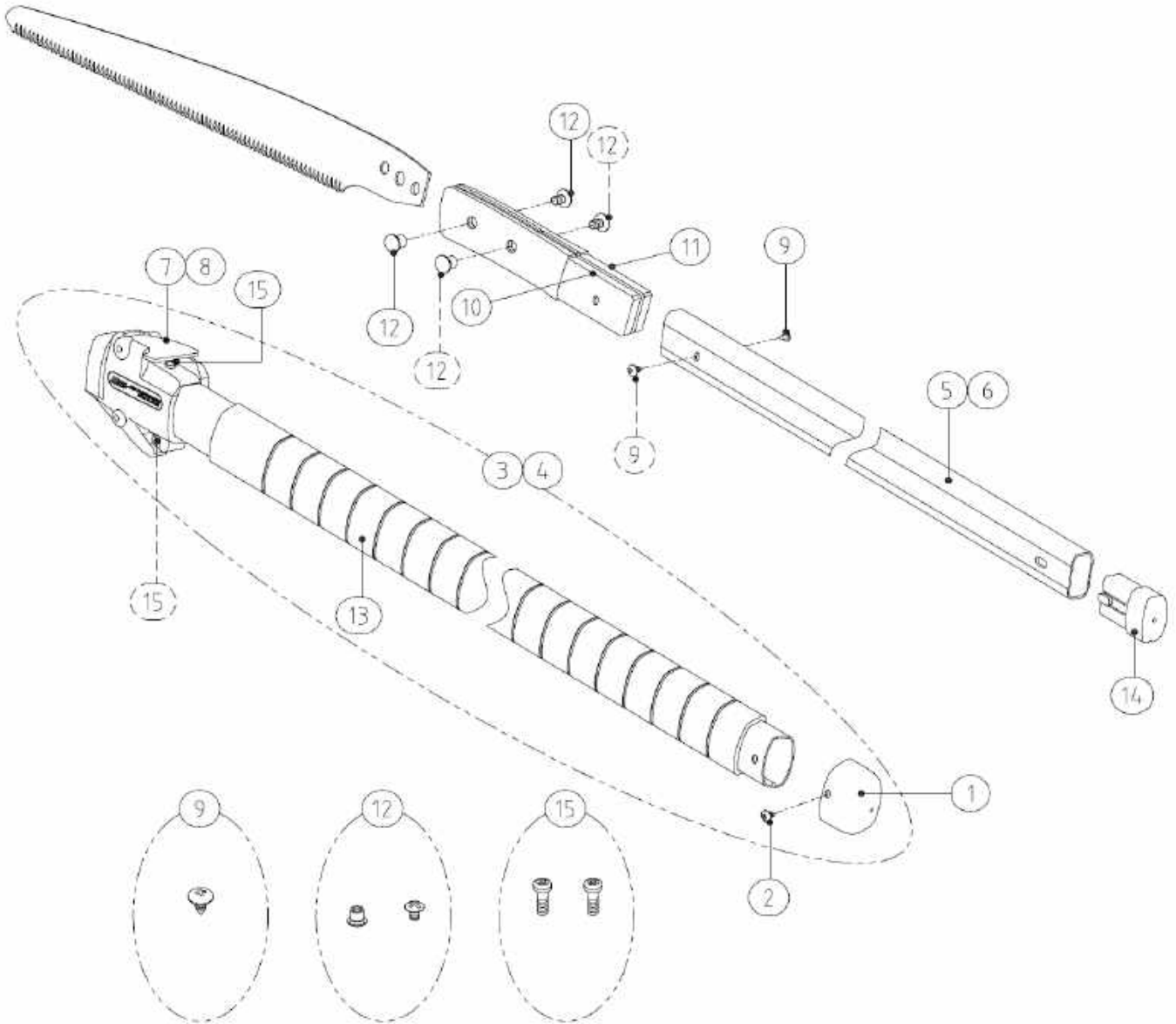

PARTS NO.	SPECIFICATION	PARTS NO.	SPECIFICATION
① SP-300	ENDCAP FOR THE BOTTOM PIPE FOR EXW-1.8/2.7	⑫ SP-308	BLADE HOLDING BOLT & NUT FOR EXW-1.8/2.7 (1PC EACH)
② SP-301	ENDCAP HOLDING SCREW FOR EXW-1.8/2.7 (1PC)	⑬ SP-309	PLASTIC GRIP ONLY FOR THE BOTTOM PIPE FOR EXW-1.8/2.7(1/2 PC.)
③ SP-302	BOTTOM GRIP SET FOR EXW-1.8 (ICL.GRIP AND JOINT CASE)	⑭ SP-310	ENDCAP FOR INNER PIPE FOR EXW-1.8/2.7
④ SP-311	BOTTOM GRIP SET EXW-2.7 (ICL.GRIP AND JOINT CASE)	⑮ SP-333	SCREW OF JOINT CASE FOR EXW-1.8/2.7 (2PCS)
⑤ SP-303	INNER PIPE FOR EXW-1.8 (W/O BLADE HOLDER)		
⑥ SP-312	INNER PIPE FOR EXW-2.7 (W/O BLADE HOLDER)		
⑦ SP-304-A	JOINT CASE FOR EXW-1.8 WITH SCREW		
⑧ SP-304-B	JOINT CASE FOR EXW-2.7 WITH SCREW		
⑨ SP-305	HOLDER FIXING BOLT & NUT FOR EXW-1.8/2.7 (1PC)		
⑩ SP-307	BLADE HOLDER(LEFT) FOR EXW-1.8/2.7		
⑪ SP-306	BLADE HOLDER(RIGHT) FOR EXW-1.8/2.7		

JGH-90

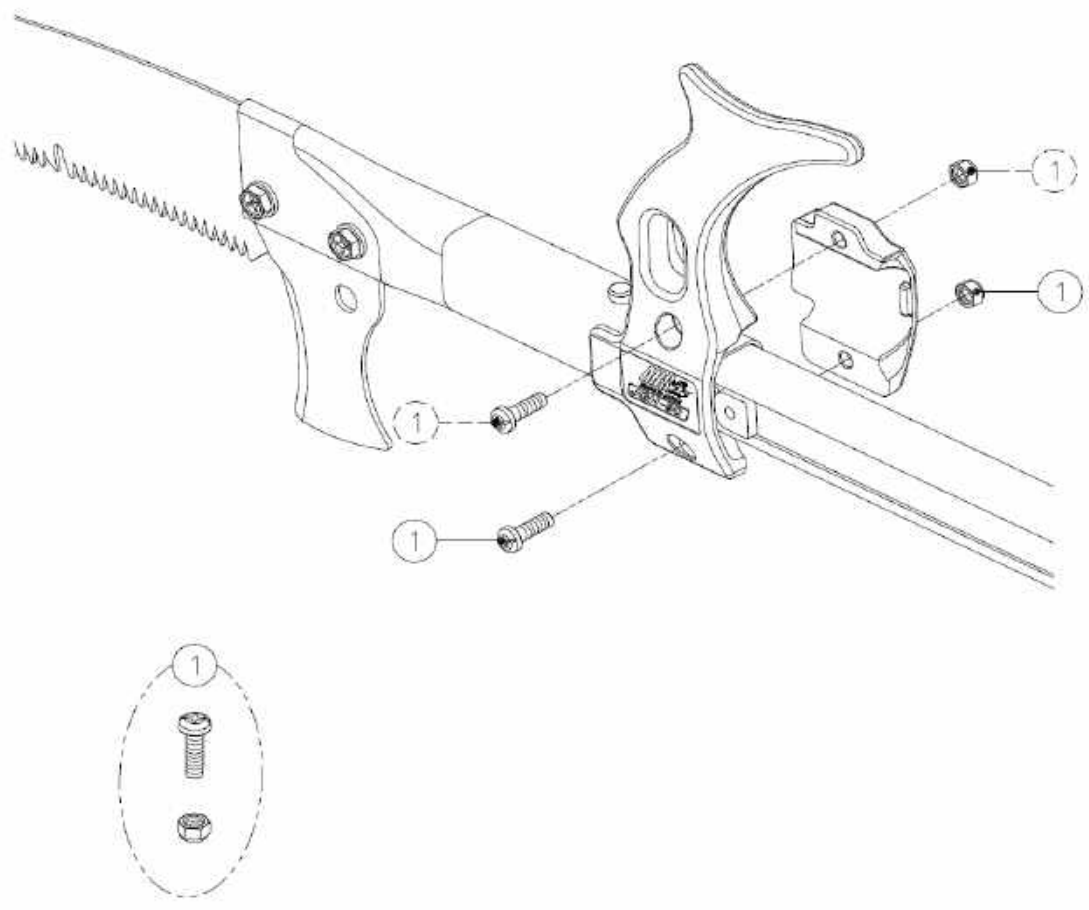

PARTS NO. SPECIFICATION	PARTS NO. SPECIFICATION
① SP-476 BOLT & NUT FOR JGH-90 (1PC EACH)	















CB-8 / CB-9

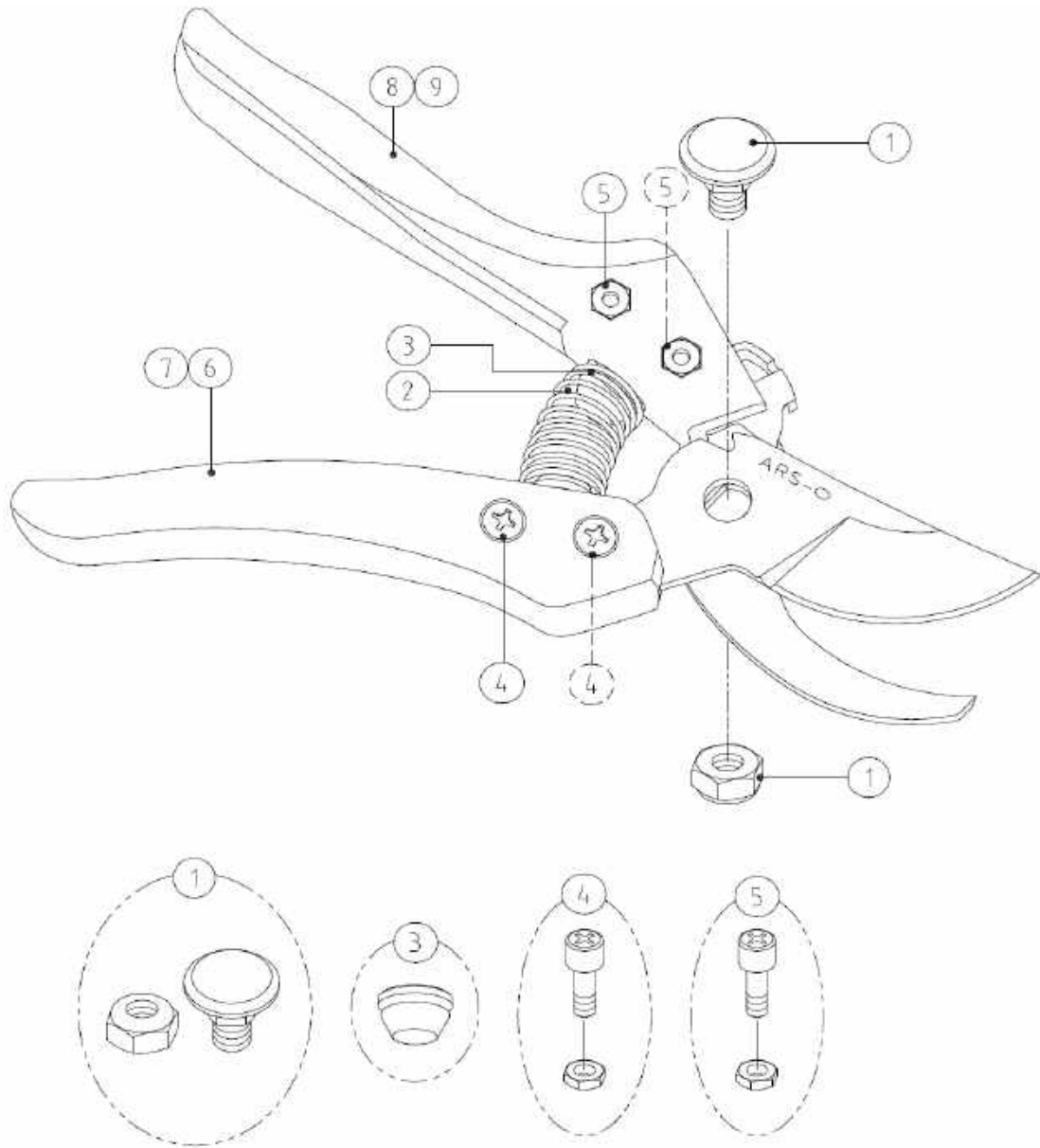

PARTS NO.	SPECIFICATION	PARTS NO.	SPECIFICATION
①	SP-217 CENTER BOLT & NUT FOR CB-8/CB-9/ CBR-8/CBR-9		
②	SP-218 SPRING FOR CB-8/CB-9/CBR-8/CBR-9		
③	SP-432 RUBBER CUSHION FOR VS-7R/7Z AND CB-8/9 (RED, 1 PC)		
④	SP-220 BOLT & NUT FOR THE CUTTING BLADE GRIP FOR CB-8/9 (1 PC EACH)		
⑤	SP-221 BOLT & NUT FOR THE COUNTER BLADE GRIP FOR CB-8/9 (1 PC EACH)		
⑥	SP-313 CUTTING BLADE GRIP FOR CB-8		
⑦	SP-315 CUTTING BLADE GRIP FOR CB-9		
⑧	SP-314 COUNTER BLADE GRIP FOR CB/CBR-8		
⑨	SP-316 COUNTER BLADE GRIP FOR CB/CBR-9		

VS-7XR / VS-8XR / VS-9XR

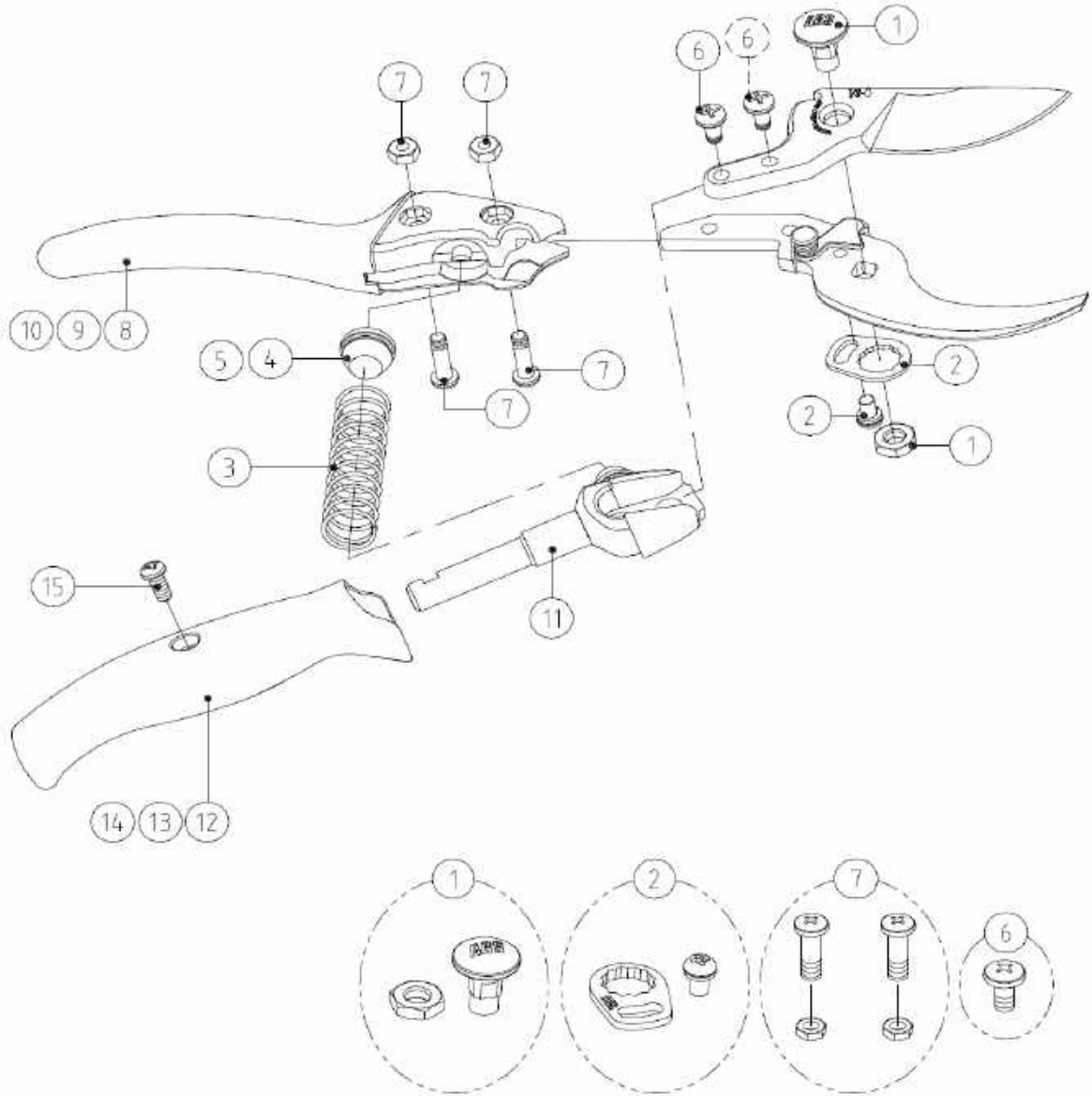

PARTS NO.	SPECIFICATION	PARTS NO.	SPECIFICATION
① SP-474	BOLT & NUT FOR VS-X SERIES	⑪ SP-398	AXLE (SHAFT) FOR ROTARY GRIP FOR VS-7R/8R/9R/7XR/8XR/9XR
② SP-475	SCREW RETAINER SET FOR VS-X SERIES	⑫ SP-416	ROTARY GRIP FOR VS-7R/7XR
③ SP-61	SPRING FOR 130DX, 140DX, 140L-DX, VS, & VS-X SERIES	⑬ SP-397	ROTARY GRIP FOR VS-8R/8XR
④ SP-151	RUBBER CUSHION FOR VS-8/9/8X/9X SERIES (BLACK, 1PC)	⑭ SP-403	ROTARY GRIP FOR VS-9R/9XR
⑤ SP-432	RUBBER CUSHION FOR CB-8/9 & VS-7R/7Z/7XR/7XZ (RED, 1PC)	⑮ SP-395	BOLT FOR ROLL GRIP OF VS-7R/8R/9R/7XR/8XR/9XR
⑥ SP-394	BLADE HOLDING BOLT FOR CUTTING BLADE OF VS-R/VX-SERIES (1PC)		
⑦ SP-323	HANDLE SCREW & NUT FOR VS/VX-SERIES (2PCS EACH)		
⑧ SP-415	COUNTER BLADE GRIP FOR VS-7Z/7R/7XZ/7XR		
⑨ SP-396	COUNTER BLADE GRIP FOR VS-8Z/8R/8XZ/8XR		
⑩ SP-402	COUNTER BLADE GRIP FOR VS-9Z/9R/9XZ/9XR		

VS-7XZ / VS-8XZ / VS-9XZ

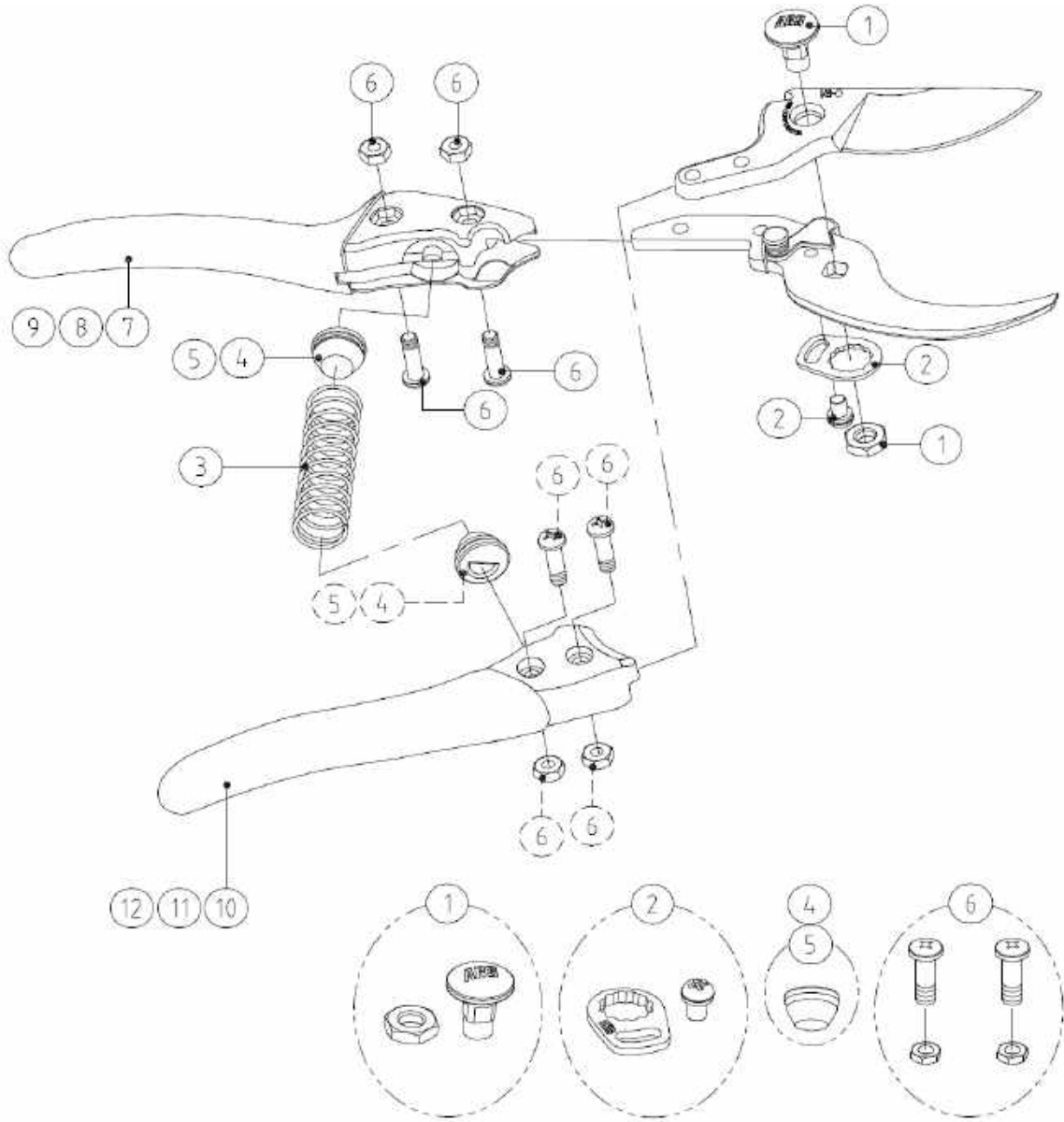

PARTS NO.	SPECIFICATION	PARTS NO.	SPECIFICATION
① SP-474	BOLT & NUT FOR VS-X SERIES		
② SP-475	SCREW RETAINER SET FOR VS-X SERIES		
③ SP-61	SPRING FOR 130DX, 140DX, 140L-DX, VS, & VS-X SERIES		
④ SP-151	RUBBER CUSHION FOR VS-8/9/8X/9X SERIES (BLACK, 1PC)		
⑤ SP-432	RUBBER CUSHION FOR CB-8/9 & VS-7R/7Z/7XR/7XZ (RED, 1PC)		
⑥ SP-323	HANDLE SCREW & NUT FOR VS/VX SERIES (2PCS EACH)		
⑦ SP-415	COUNTER BLADE GRIP FOR VS-7Z/7R/7XZ/7XR		
⑧ SP-396	COUNTER BLADE GRIP FOR VS-8Z/8R/8XZ/8XR		
⑨ SP-402	COUNTER BLADE GRIP FOR VS-9Z/9R/9XZ/9XR		
⑩ SP-417	CUTTING BLADE GRIP FOR VS-7Z/7XZ		
⑪ SP-401	CUTTING BLADE GRIP FOR VS-8Z/8XZ		
⑫ SP-404	CUTTING BLADE GRIP FOR VS-9Z/9XZ		







160-0.35 / 160-0.6 / 160-1.2 / 160-1.8 / 160-2.4 / 180-1.2 / 180-1.8 / 180-2.4

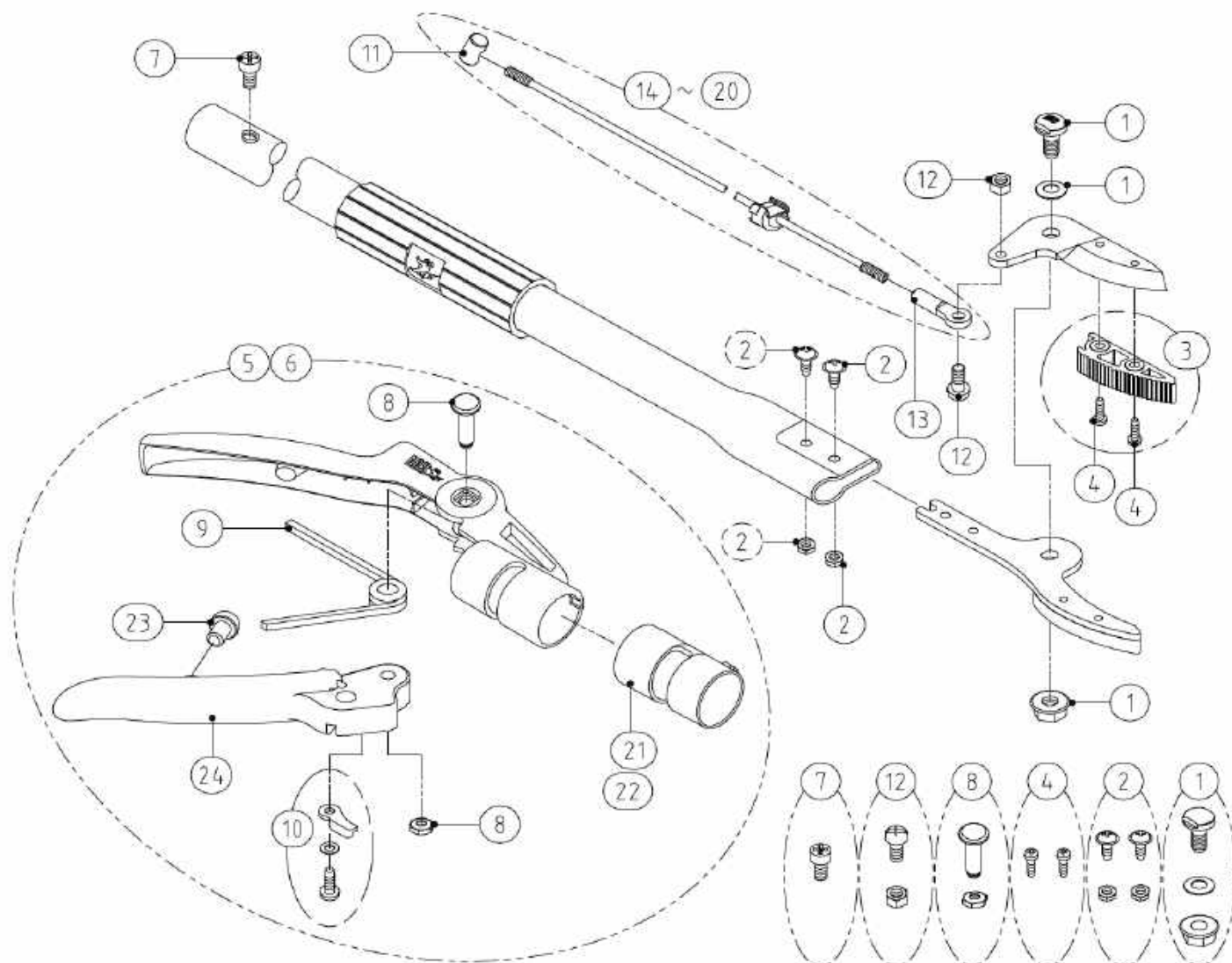

PARTS NO.	SPECIFICATION	PARTS NO.	SPECIFICATION
① SP-30	BOLT,WASHER & NUT FOR 160/180 SERIES	⑪ SP-43	ROD FIXING PART FOR LONG REACH PRUNER
② SP-31	SCREW & NUT FOR 160/180 SERIES (2PCS EACH)	⑫ SP-44	ROD FIXING BOLT & NUT FOR 150/160/180/ 190/ZF SERIES
③ SP-32	HOLDING DEVICE OF THE CUTTING BLADE WITH 2 SCREWS FOR 160 SERIES	⑬ SP-45	ROD CAP FOR LONG REACH PRUNER
④ SP-33	SCREW FOR 160 SERIES (2PCS)	⑭ SP-46	ROD SET FOR 160/180-1.8
⑤ SP-38-A	HANDLE SET FOR LONG REACH PRUNER, FOR 160-0.35/0.6/1.2/1.8	⑮ SP-48	ROD SET FOR 160/180-2.4
⑥ SP-38-B	HANDLE SET FOR LONG REACH PRUNER, FOR 160-1.8/2.4 & 180 SERIES	⑯ SP-81	ROD SET FOR 160-0.35
⑦ SP-452	STOP SCREW FOR THE HANDLE OF 180LR/ZF/160/180 SERIES	⑰ SP-82	ROD SET FOR 160-0.6
⑧ SP-40	SCREW & NUT FOR THE HANDLE OF LONG REACH PRUNER	⑱ SP-83	ROD SET FOR 160/180-1.2
⑨ SP-41	SPRING FOR LONG REACH PRUNER (INC ZR SERIES,150-0.6) (1 PC)	⑲ SP-84	ROD SET FOR 160/180-2.1
⑩ SP-42	LATCH LOCK SET OF THE HANDLE FOR LONG REACH PRUNER	⑳ SP-153	ROD SET FOR 160-1.5
		㉑ SP-169	SLEEVE FOR THE GRIP OF 160-0.35/0.6/ 1.2/1.8 SERIES
		㉒ SP-168	SLEEVE FOR THE GRIP OF 160-2.1/2.4/ 180/190 SERIES
		㉓ SP-80	RUBBER CUSHION FOR THE HANDLE OF LONG REACH PRUNER
		㉔ SP-145	GRIP LEVER ONLY FOR 160/180/180L SERIES



150-0.6

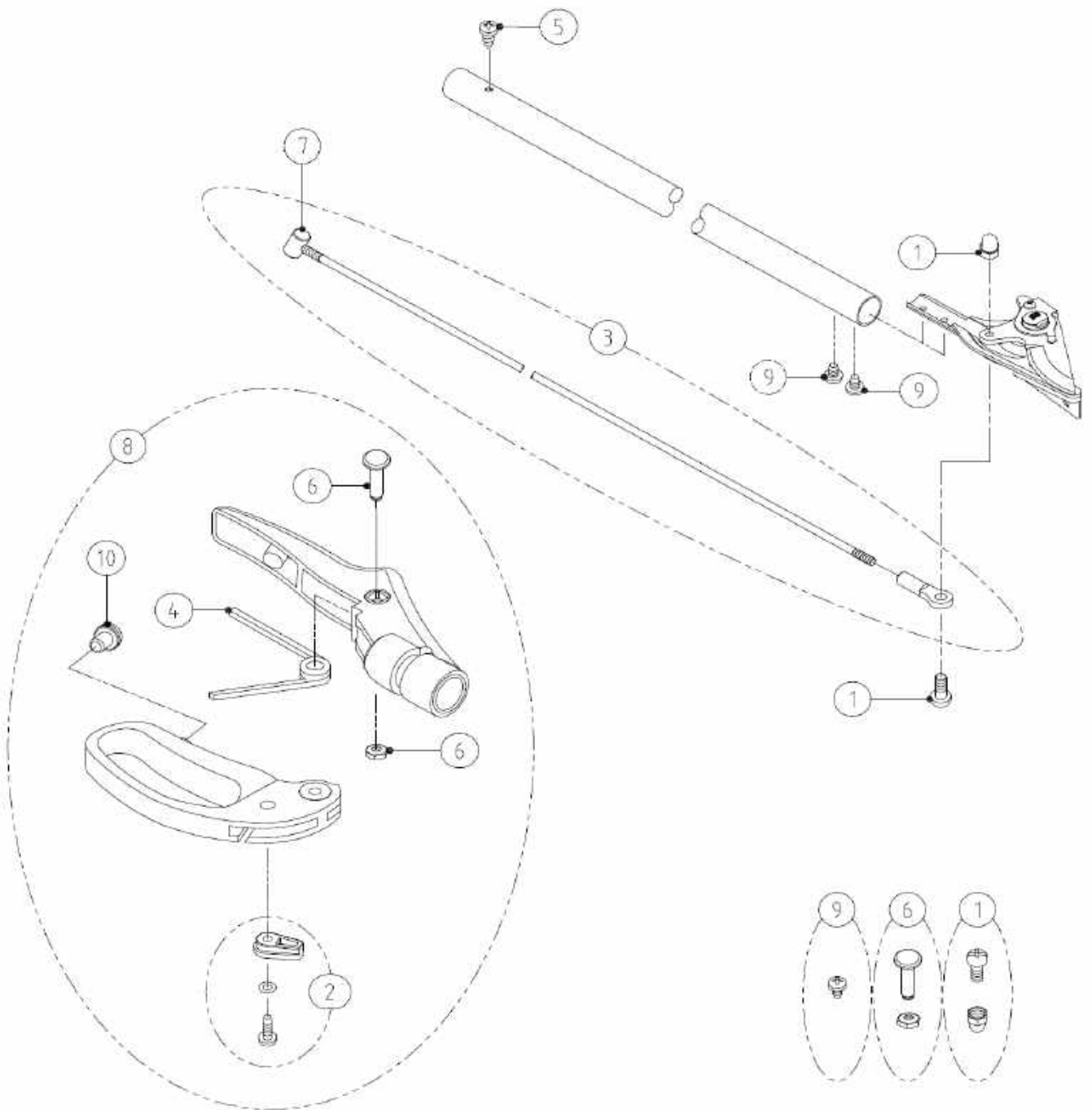

PARTS NO.	SPECIFICATION	PARTS NO.	SPECIFICATION
① SP-44	ROD FIXING BOLT & NUT FOR 150/160/ 180/190/ZF SERIES	⑩ SP-80	RUBBER CUSHION FOR THE HANDLE OF LONG REACH PRUNER
② SP-175	LATCH LOCK SET FOR THE HANDLE OF 150-0.6		
③ SP-125	ROD SET FOR 150-0.6		
④ SP-41	SPRING FOR LONG REACH PRUNER (INC ZR SERIES,150-0.6) (1 PC)		
⑤ SP-473	STOP SCREW FOR 150-0.6		
⑥ SP-40	SCREW & NUT FOR THE HANDLE OF LONG REACH PRUNER		
⑦ SP-43	ROD FIXING PART FOR LONG REACH PRUNER		
⑧ SP-123	HANDLE SET FOR 150-0.6		
⑨ SP-174	SCREW TO ATTACH CUTTING HEAD FOR 150-0.6 (1PC)		

160ZF-2.0-3 / 160ZF-3.0-5 / 180ZF-2.0-3 / 180ZF-3.0-5

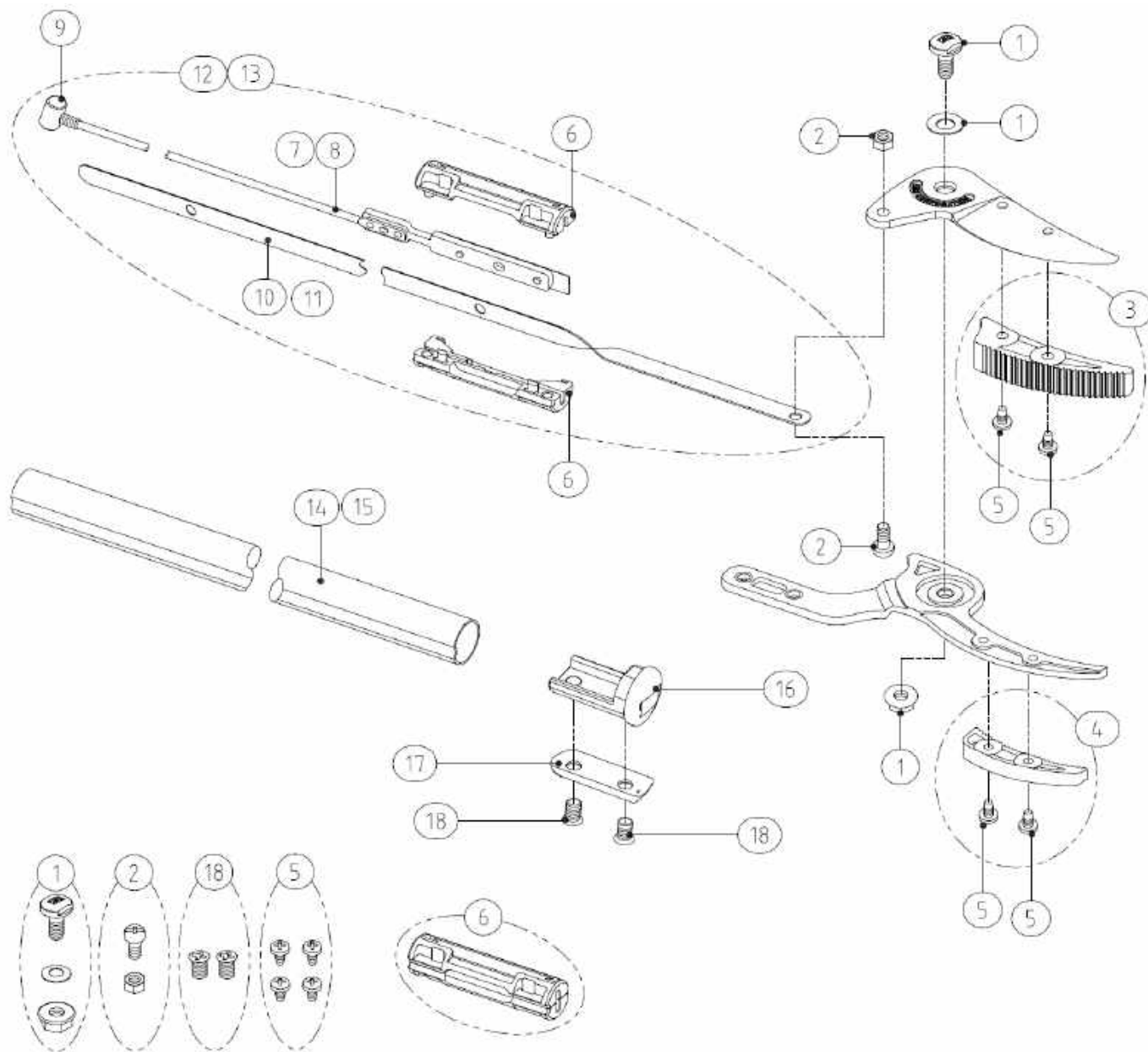

PARTS NO.	SPECIFICATION	PARTS NO.	SPECIFICATION
① SP-334	BOLT,WASHER & NUT FOR ZR/ZF SERIES	⑫ HP-ZF-2.0-3	STEEL BAND SET FOR ZF-2.0-3
② SP-44	ROD FIXING BOLT & NUT FOR 150/160/180/ 190/ZF SERIES	⑬ HP-ZF-3.0-5	STEEL BAND SET FOR ZF-3.0-5
③ SP-351	HOLDING DEVICE FOR THE CUTTING BLADE WITH 2 SCREW FOR 160ZR/ZF	⑭ SP-463	UPPER PIPE FOR 160/180ZF-2.0-3
④ SP-352	HOLDING DEVICE FOR THE COUNTER BLADE WITH 2 SCREW FOR 160ZR/ZF	⑮ SP-464	UPPER PIPE FOR 160/180ZF-3.0-5
⑤ SP-353	SCREWS FOR HOLDING DEVICE OF 160ZR/ZF/ 160R-1.8 (4PCS)	⑯ SP-465	BLADE FIXING PART FOR ZF SERIES
⑥ SP-335	INNER CASE FOR ZR/ZF SERIES	⑰ SP-466	WASHER PLATE FOR BLADE FIXING PART OF ZF SERIES
⑦ SP-459	ROD ONLY, FOR 160/180ZF-2.0-3	⑱ SP-399	SCREW FOR THE BLADE FIXING PART OF 160R/180R/ZF SERIES (2PCS)
⑧ SP-460	ROD ONLY, FOR 160/180ZF-3.0-5		
⑨ SP-338	ROD FIXING PART FOR ZR/ZF/160R/180R/ 180LR SERIES		
⑩ SP-461	STEEL BAND ONLY, FOR 160/180ZF-2.0-3		
⑪ SP-462	STEEL BAND ONLY, FOR 160/180ZF-3.0-5		

160ZF-2.0-3 / 160ZF-3.0-5 / 180ZF-2.0-3 / 180ZF-3.0-5

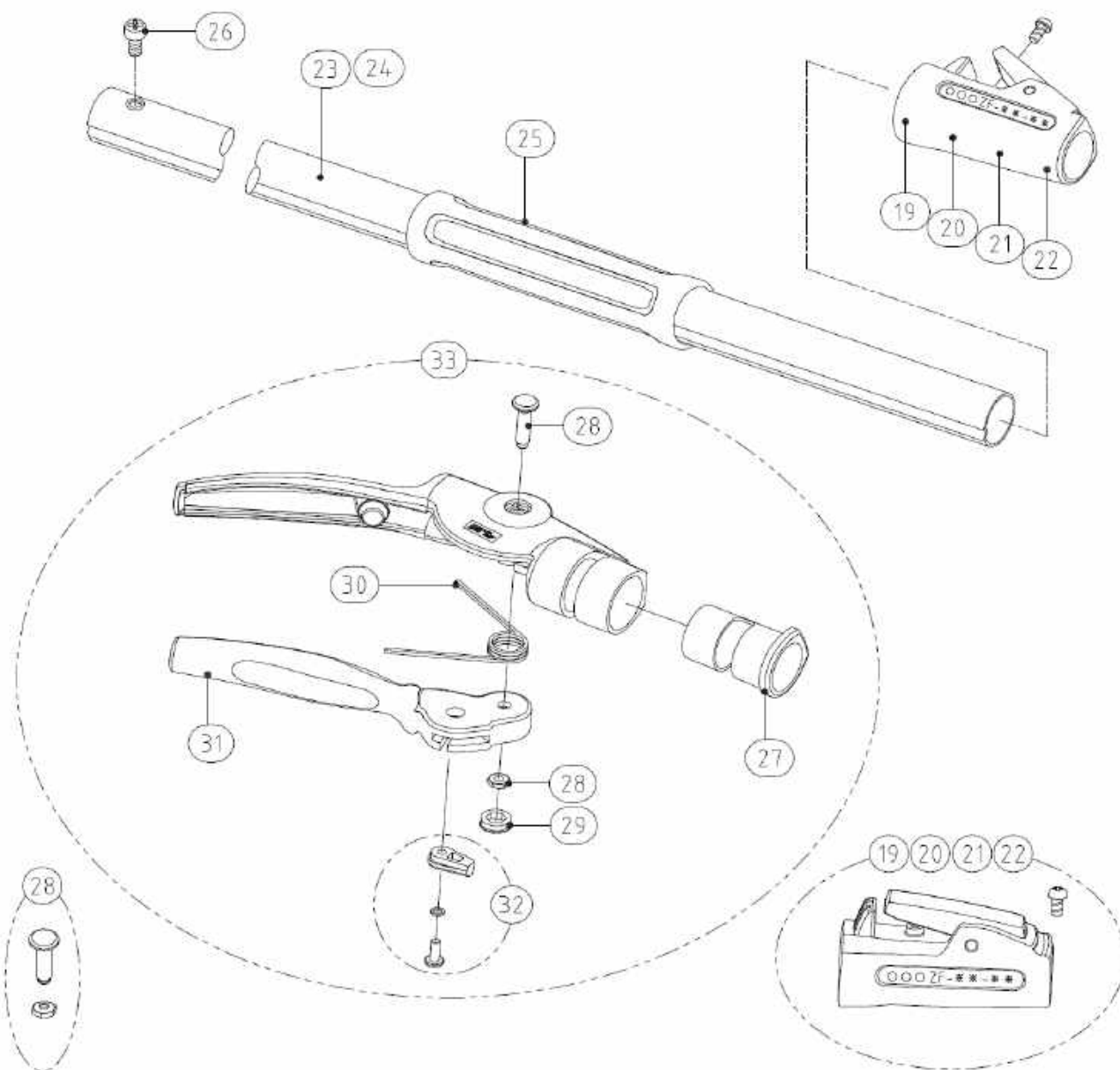

PARTS NO.	SPECIFICATION	PARTS NO.	SPECIFICATION		
①⑨	SP-467	JOINT CASE SET FOR 160ZF-2.0-3	③①	SP-349	GRIP LEVER ONLY, FOR ZR/ZF/160R/180R/180LR SERIES
②⑩	SP-468	JOINT CASE SET FOR 160ZF-3.0-5			
②⑪	SP-469	JOINT CASE SET FOR 180ZF-2.0-3	③②	SP-380	HANDLE LATCH LOCK SET FOR ZR/ZF/160R/180R/180LR SERIES
②⑫	SP-470	JOINT CASE SET FOR 180ZF-3.0-5			
②⑬	SP-471	LOWER PIPE ONLY, FOR 160/180ZF-2.0-3	③③	SP-348	GRIP SET FOR ZR/ZF/160R/180R/180LR SERIES
②⑭	SP-472	LOWER PIPE ONLY, FOR 160/180ZF-3.0-5			
②⑮	SP-350	MIDDLE GRIP FOR ZR/ZF/160R/180R			
②⑯	SP-452	STOP SCREW FOR THE HANDLE OF 180LR/ZF SERIES			
②⑰	SP-339	SLEEVE FOR THE GRIP OF ZR/ZF/160R/180R/180LR SERIES			
②⑱	SP-379	CENTER BOLT & NUT FOR GRIP OF ZR/ZF/160R/180R/180LR SERIES			
②⑲	SP-414	NUT CAP FOR THE HANDLE OF ZR/ZF/160R/180R/180LR SERIES			
③①	SP-41	SPRING FOR LONG REACH PRUNER (INC ZR SERIES,150-0.6) (1 PC)			

160R-1.8 / 180R-1.8

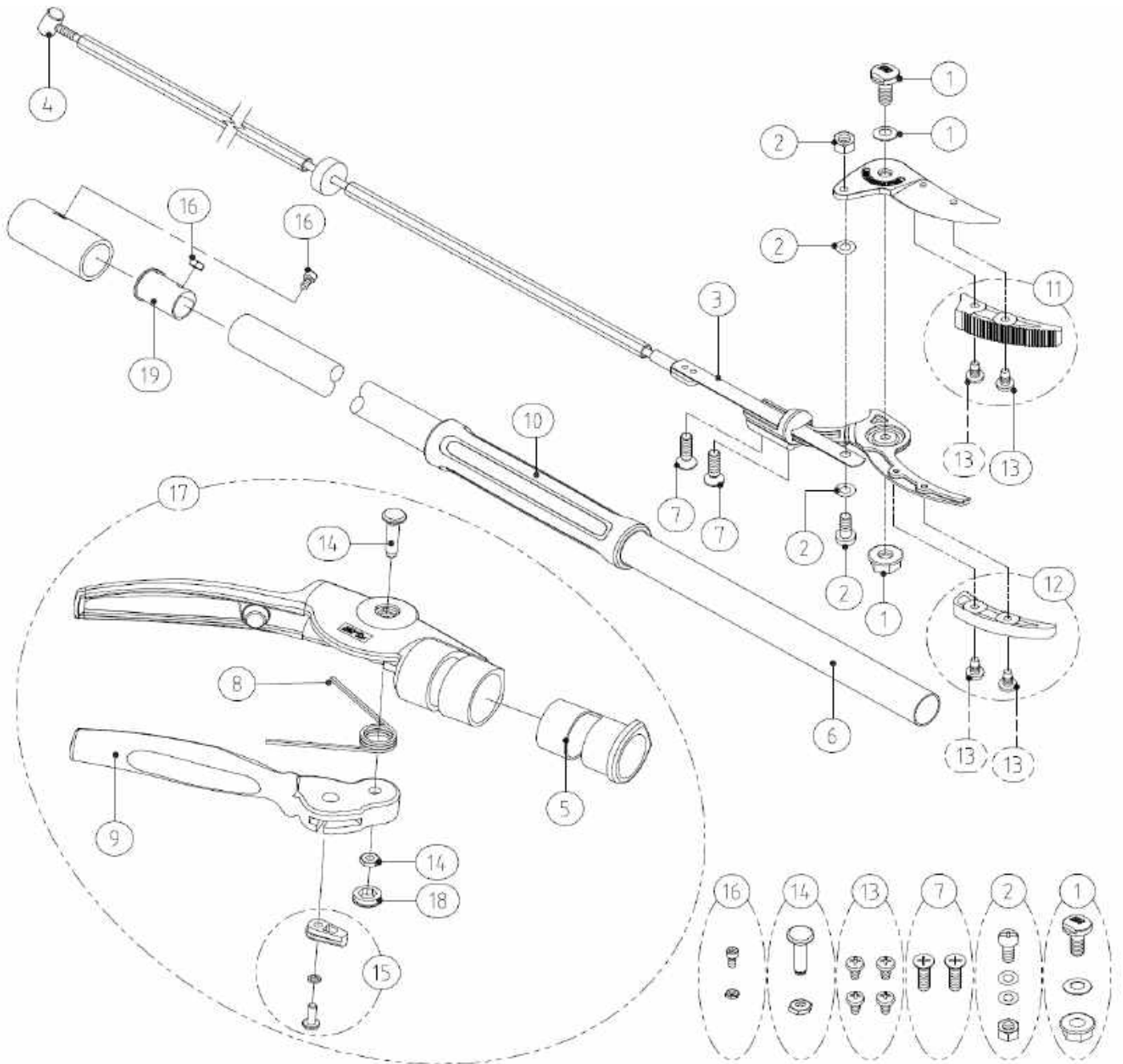

PARTS NO.	SPECIFICATION	PARTS NO.	SPECIFICATION
① SP-334	BOLT,WASHER & NUT FOR ZR/ZF SERIES	⑪ SP-351	HOLDING DEVICE FOR THE CUTTING BLADE WITH 2 SCREW FOR 160ZR/ZF
② SP-74	SCREW,NUT & 2 WASHERS FOR THE HOOP OF ZR SERIES/160R-1.8/180R-1.8	⑫ SP-352	HOLDING DEVICE FOR THE COUNTER BLADE WITH 2 SCREW FOR 160ZR/ZF
③ SP-392	ROD FOR 160R/180R-1.8	⑬ SP-353	SCREWS FOR HOLDING DEVICE OF 160ZR/ZF 160R-1.8 (4PCS)
④ SP-338	ROD FIXING PART FOR ZR/ZF/160R/180R SERIES	⑭ SP-379	CENTER BOLT & NUT FOR GRIP OF ZR/ZF/160R/180R/180LR SERIES
⑤ SP-339	SLEEVE FOR THE GRIP OF ZR/ZF/160R/180R SERIES	⑮ SP-380	HANDLE LATCH LOCK SET FOR ZR/ZF/160R/180R/180LR SERIES
⑥ SP-393	PIPE FOR 160R/180R-1.8	⑯ SP-400	STOP SCREW & NUT FOR 160R/180R
⑦ SP-399	SCREW TO ATTACHED CUTTING BLADE FOR 160R/180R/ZF (2PCS)	⑰ SP-348	GRIP SET FOR ZR/ZF/160R/180R/180LR SERIES
⑧ SP-41	SPRING FOR LONG REACH PRUNER (INC ZR SERIES,150-0.6) (1 PC)	⑱ SP-414	NUT CAP FOR THE HANDLE OF ZR/ZF/160R/180R/180LR SERIES
⑨ SP-349	GRIP LEVER ONLY FOR ZR/ZF/160R/180R SERIES	⑲ SP-418	SLEEVE FOR STOP SCREW & NUT OF 160R/180R-1.8
⑩ SP-350	MIDDLE GRIP FOR ZR/ZF/160R/180R		

180LR-1.2/1.8/2.1

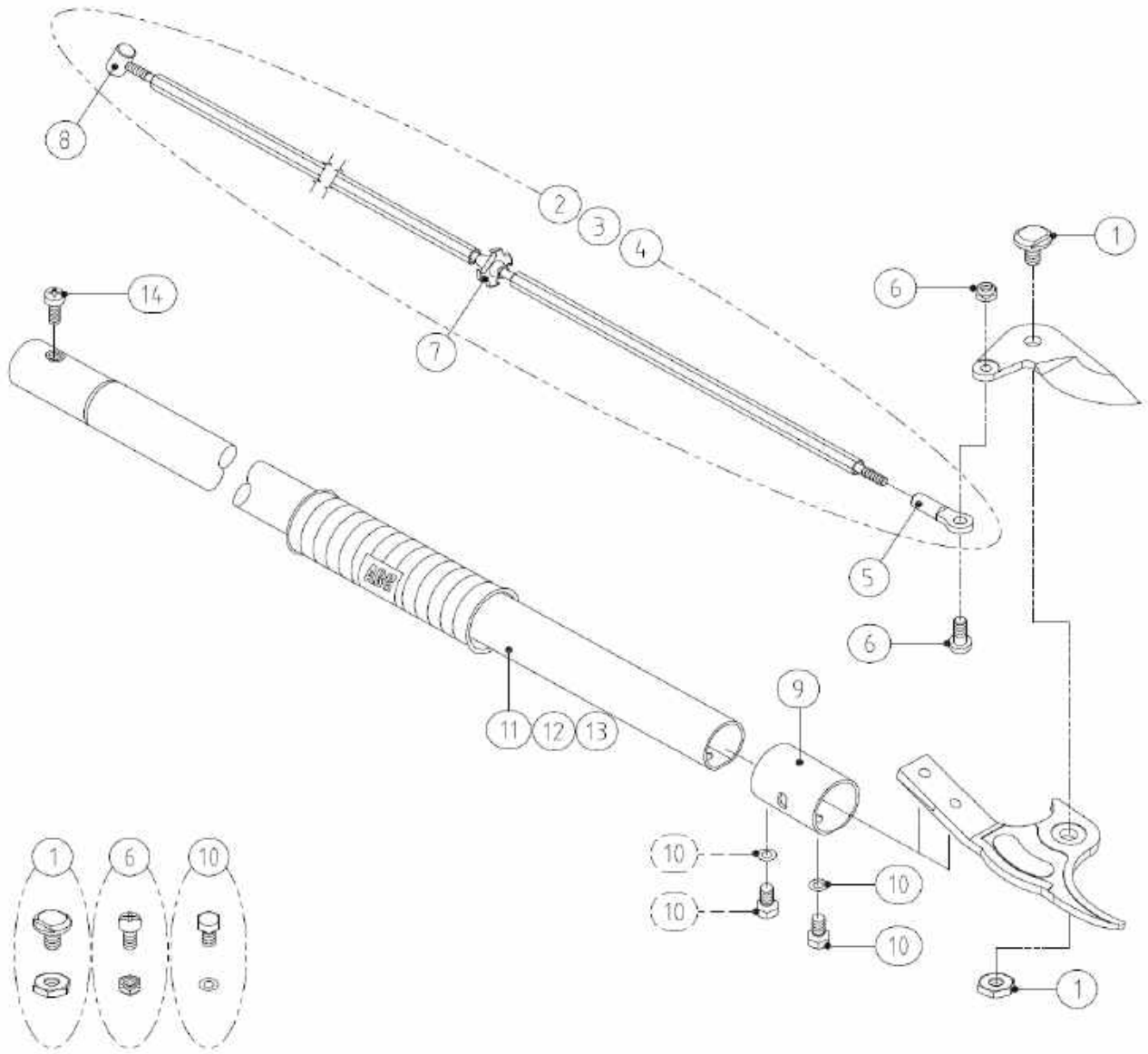

PARTS NO.	SPECIFICATION	PARTS NO.	SPECIFICATION
①	SP-216 BOLT & NUT FOR 180L/LR SERIES		
②	SP-446 ROD SET FOR 180LR-1.2		
③	SP-447 ROD SET FOR 180LR-1.8		
④	SP-448 ROD SET FOR 180LR-2.1		
⑤	SP-264 ROD CAP FOR 180L/LR SERIES		
⑥	SP-259 ROD FIXING BOLT & NUT FOR 180L/LR SERIES		
⑦	SP-235 ROD HOLDING DISK FOR 180L/LR SERIES		
⑧	SP-338 ROD FIXING PART FOR ZR/ZF/160R/180R/ 180LR SERIES		
⑨	SP-435 BLADE FIXING COLLAR FOR 180L/LR SERIES		
⑩	SP-239 BLADE HOLDING BOLT & WASHER FOR 180L/ LR SERIES (1 PC EACH)		
⑪	SP-449 PIPE FOR 180LR-1.2 WITH MIDDLE GRIP		
⑫	SP-450 PIPE FOR 180LR-1.8 WITH MIDDLE GRIP		
⑬	SP-451 PIPE FOR 180LR-2.1 WITH MIDDLE GRIP		
⑭	SP-452 STOP SCREW FOR THE HANDLE OF 180LR SERIES		



185-1.2 / 185-1.5 / 185-1.8

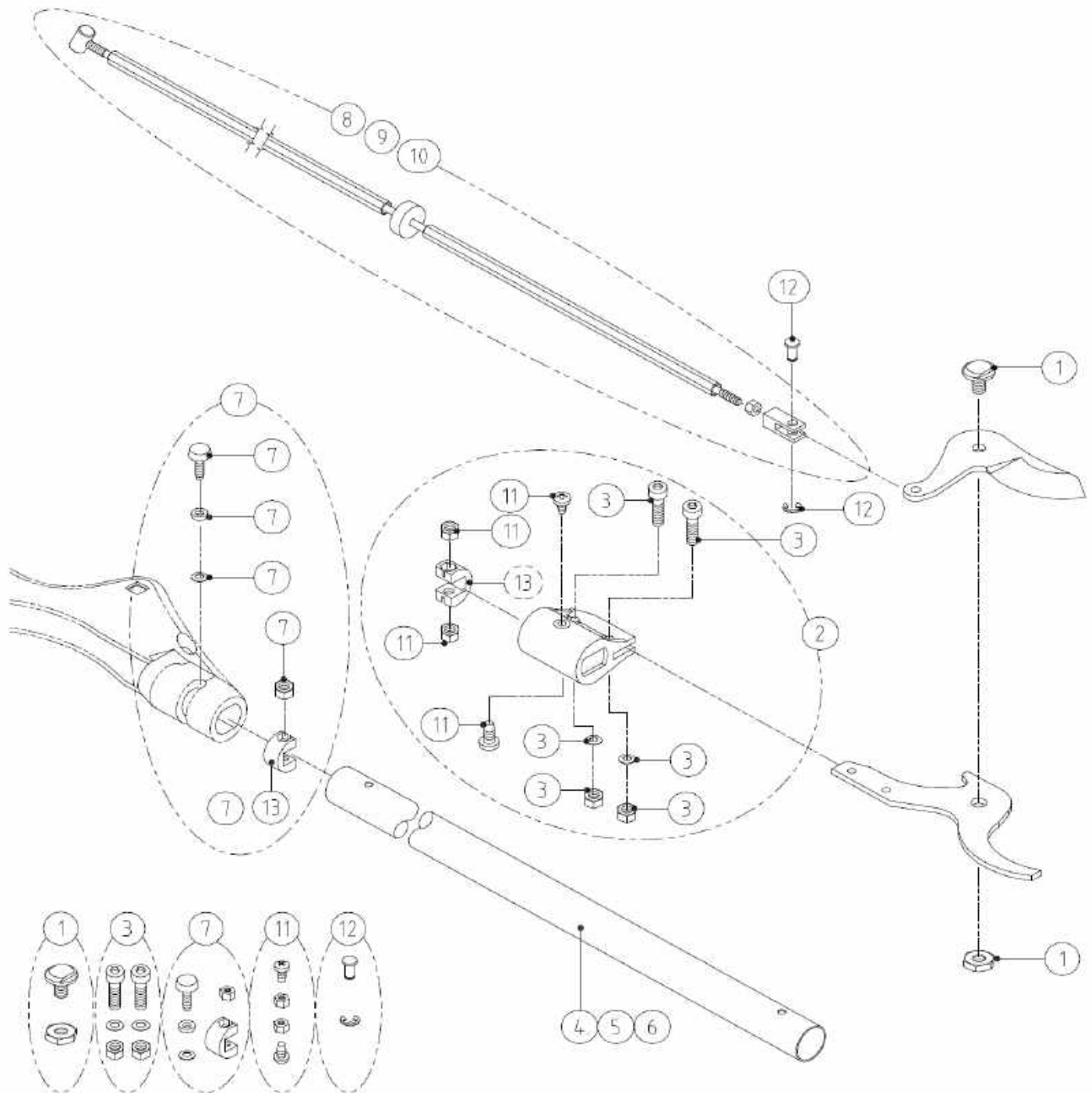

PARTS NO.	SPECIFICATION	PARTS NO.	SPECIFICATION
① SP-205	BOLT & NUT FOR 185-1.2/185-1.5/185-1.8	⑪ SP-240	BOLT & NUT FOR FITTING PARTS SET FOR 185 SERIES (2PCS EACH)
② SP-206	FITTING PARTS SET FOR 185-1.2/185-1.5/185-1.8	⑫ SP-163	ROD FIXING PIN & STOPPER FOR 185 SERIES
③ SP-207	CAP BOLT, NUT & WASHER FOR 185-1.2/185-1.5/185-1.8 (2PCS EACH)	⑬ SP-412	ROD GUIDE FOR 185 SERIES (1PC)
④ SP-208	PIPE FOR 185-1.2		
⑤ SP-209	PIPE FOR 185-1.5		
⑥ SP-210	PIPE FOR 185-1.8		
⑦ SP-213	BOLT, NUT, TUBE, WASHER & ROD GUIDE FOR 185 SERIES		
⑧ SP-230	ROD SET FOR 185-1.2		
⑨ SP-231	ROD SET FOR 185-1.5		
⑩ SP-232	ROD SET FOR 185-1.8		

185-1.2 / 185-1.5 / 185-1.8

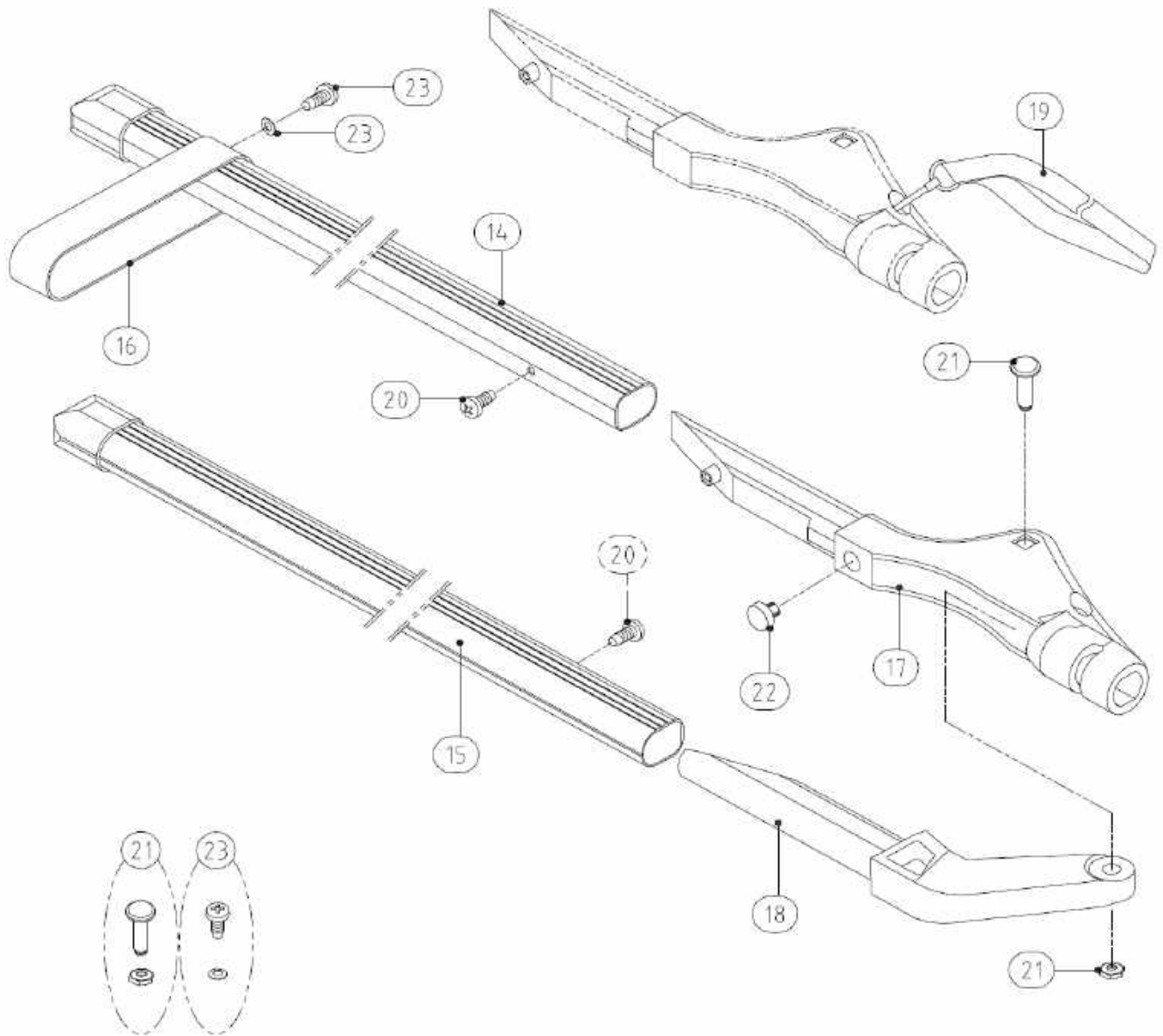

PARTS NO.	SPECIFICATION	PARTS NO.	SPECIFICATION
⑭ SP-211	LEVER PIPE 1 WITH END CAP FOR 185-1.2/ 185-1.5/185-1.8		
⑮ SP-212	LEVER PIPE 2 WITH END CAP FOR 185-1.2/ 185-1.5/185-1.8		
⑯ SP-214	STOPPER BAND ONLY, FOR 185-1.2/185-1.5/ 185-1.8		
⑰ SP-252	GRIP ONLY FOR 185-1.2/185-1.5/185-1.8		
⑱ SP-253	LEVER ONLY FOR 185-1.2/185-1.5/185-1.8		
⑲ SP-254	STRAP FOR 185 SERIES		
⑳ SP-318	BOLT FOR LEVER PIPE FOR 185 SERIES (1PC)		
㉑ SP-319	BOLT & NUT FOR GRIP OF 185 SERIES		
㉒ SP-411	RUBBER CUSHION FOR THE HANDLE OF 185 SERIES		
㉓ SP-413	BOLT & NUT FOR THE STOPPER BAND OF 185 SERIES		







K-900Z

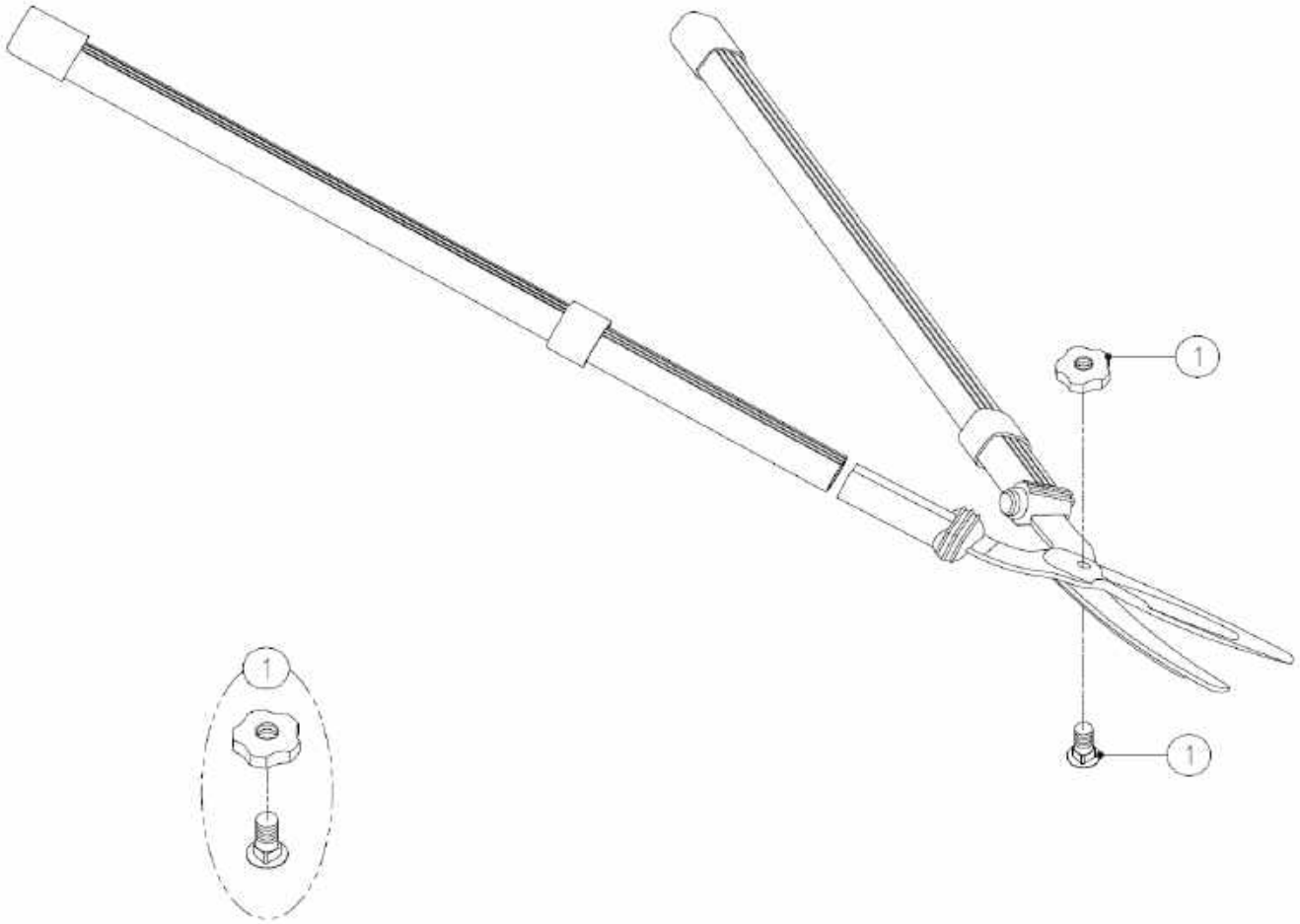

PARTS NO. SPECIFICATION	PARTS NO. SPECIFICATION
① SP-58 BOLT & NUT FOR K-800/K-900Z/K-950Z	

LPB-20S / LPB-20M / LPB-20L

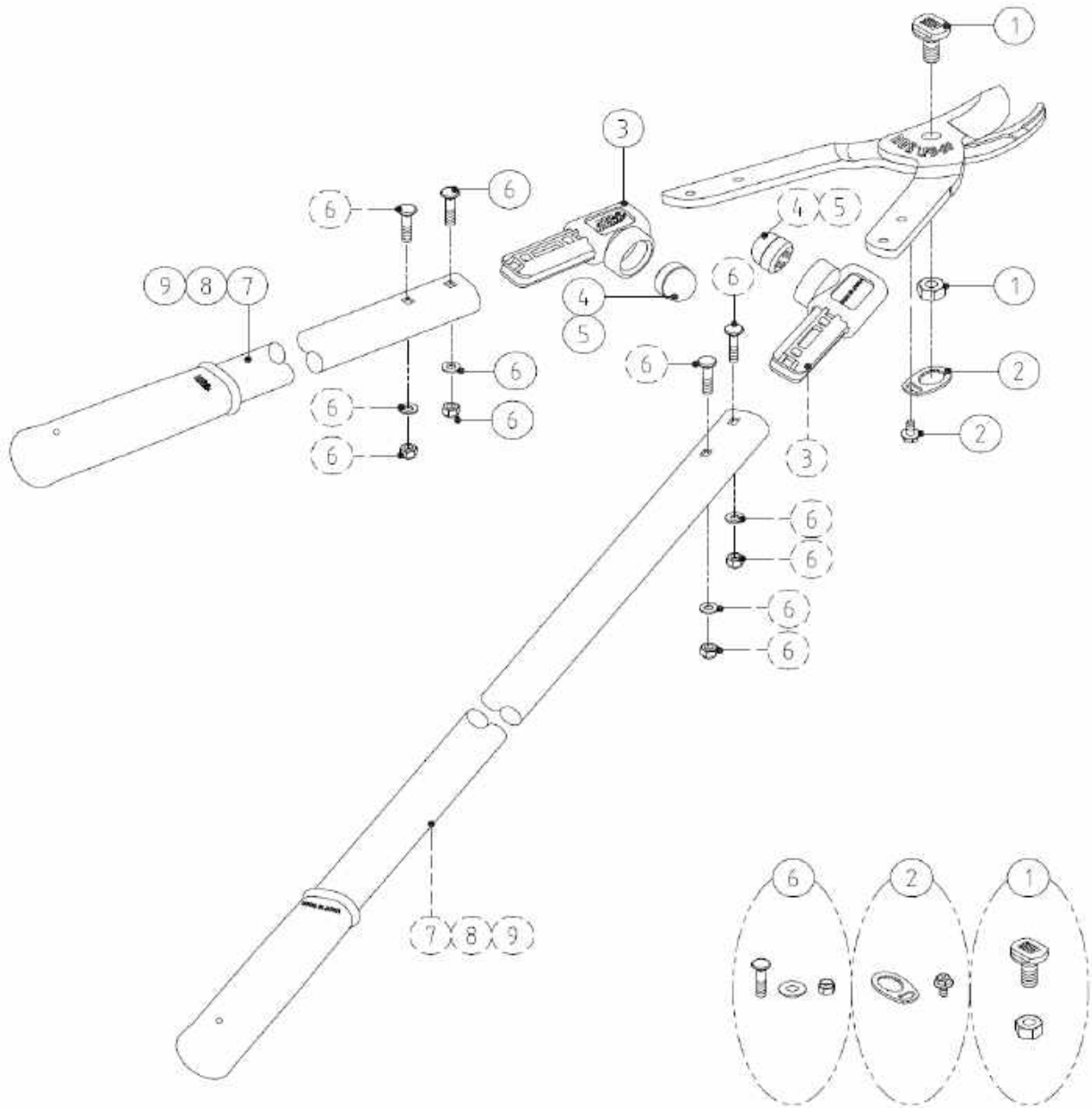

PARTS NO.	SPECIFICATION	PARTS NO.	SPECIFICATION
①	SP-288 CENTRE BOLT & NUT FOR LPB SERIES		
②	SP-426 SCREW RETAINER SET FOR LPB SERIES & LPA-30L		
③	SP-419 BUMPER SOCKET FOR LPB SERIES (1 PC)		
④	SP-420 SHOCK ABSORBER FOR LPB-20S/30S (1 PC)		
⑤	SP-421 SHOCK ABSORBER FOR LPB-20M/L AND LPB-30M/L (1 PC)		
⑥	SP-387 BLADE HOLDING BOLT, NUT & WASHER FOR LPA-30L AND LPB SERIES (/ 1 PC)		
⑦	SP-422 PIPE WITH GRIP FOR LPB-20S/30S (1 PC)		
⑧	SP-423 PIPE WITH GRIP FOR LPB-20M/30M (1 PC)		
⑨	SP-389 PIPE WITH GRIP FOR LPA-30L & LPB-20L/30L (1 PC)		





LPA-30L

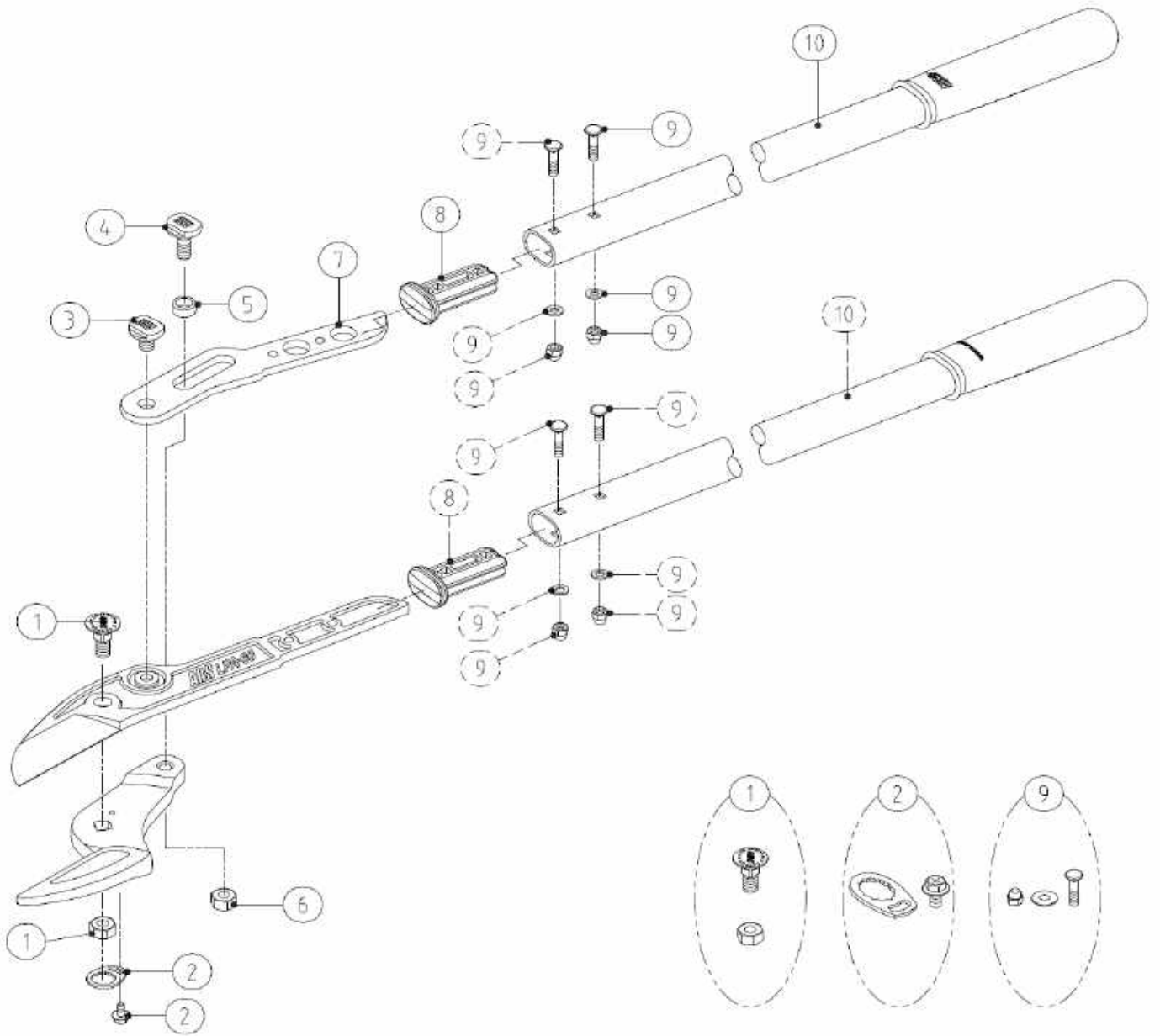

PARTS NO.	SPECIFICATION	PARTS NO.	SPECIFICATION
①	SP-278 CENTER BOLT & NUT FOR LP-40 & LPA-30L		
②	SP-426 SCREW RETAINER SET FOR LPB SERIES & LPA-30L		
③	SP-385 FULCRUM BOLT OF LINK FOR LPA-30L		
④	SP-382 FIXING BOLT FOR LINK & COUNTER BLADE OF LPA-30L		
⑤	SP-386 LINK SPACER FOR LPA-30L		
⑥	SP-383 FIXING NUT FOR LINK & COUNTER BLADE OF LPA-30L		
⑦	SP-384 LINK FOR LPA-30L		
⑧	SP-388 BLADE HOLDING SOCKET FOR LPA-30L(1PC)		
⑨	SP-387 BLADE HOLDING BOLT,NUT & WASHER FOR LPA-30L AND LPB SERIES(/ 1PC)		
⑩	SP-389 PIPE WITH GRIP FOR LPA-30L & LPB-20L/30L (1PC)		

